

TITAN

OWNERS MANUAL
FOR PROFESSIONAL
USE ONLY

313 - 247 REV 12/91

DO NOT USE EQUIPMENT BEFORE READING THIS MANUAL

Elite E200

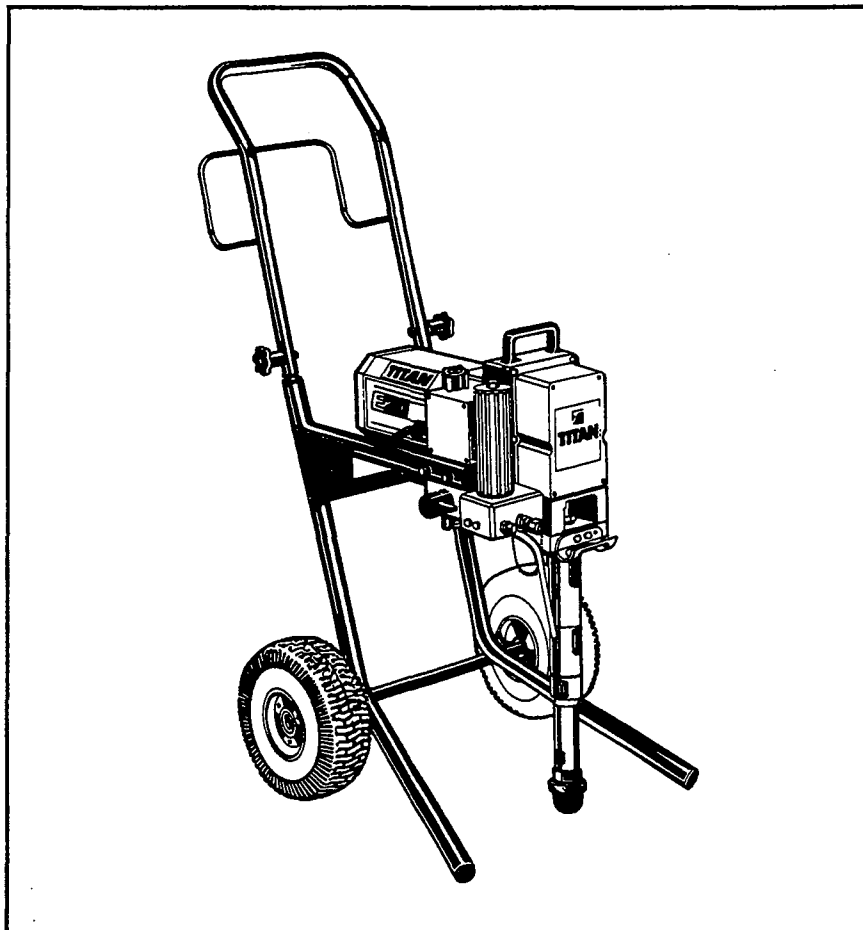

Pump Only - 761-502
Complete - 761-500

220V Pump Only 761- 238
220 V Complete 761 -240

This manual contains important warnings and instructions,
please read and retain for reference.

Never operate this unit unless it is properly grounded.

Table of Contents

Accessories	2	Parts Drawings &	
General Repairs/Service	3	Repair Information	16 - 25
Maintenance/Service Record	4	Frame	16
Warnings	5	Replacement Labels	16
Aviso (En Espanol)	6	Unitec Motor	18 & 19
Attention (En Francaise)	7	Armature	18
Notice: Fire or Explosion		Motor Housing	19
Hazards	8 & 9	Gears Box	20 & 21
Start-up Procedure	10	Gear Repair Service	21
Cleaning Procedure	11	On/Off Switch	21
Flushing Specifications	12	Power Cord Replacement	21
Application Techniques	12 & 13	Wiring Diagram	20
Airless Tip Selection	14	Motor Starter	21
Trouble Shooting	14 & 15	Filter Block	22 & 23
Spray Pattern		Pressure Switch	23
Airless Gun		Pressure Relief Prime Valve	23
Airless Pump		Gun Filter	23
		Fluid Section	24 & 25
		Seat Service & Repair	25
		Pump Sect. Repair/Packings	25
		Job History Recording form	26
		Specifications	27
		Warranty	27

Accessories

LIQUID SHIELD

Cleans and protects spray systems against rust, corrosion and premature wear.

Case of 12 (1 quart bottles) 700-888
1 quart 700-889



PISTON SEAL LUBRICANT

Specially formulated to prevent materials from adhering to the piston rod, which becomes abrasive to the upper seals. Piston Lube will break down any material that may accumulate in the wet cup and keep it from drying.

8 oz individual 700-925
1 qt individual 700-926
8 oz, case of 12 700-911
1 qt, case of 12 700-912



AIRLESS HOSE

I.D. x Length	Product No
1/4" x 50'	316-505
3/8" x 50'	690-375-50
3/16" x 3'	550-220
3/16" x 9'	550-222
3/16" x 15'	550-221

HIGH PRESSURE SWIVELS

Pressure Rated at 5000 psi

Gun-to-Hose

1/4" NPS (F) x 1/4" NPS (M) 500-428

Hose-to-Hose

1/4" NPS (M) x 1/4" NPS (M) 500-424

FITTINGS

1/4" x 1/4" Hose Coupling	490-012
1/4" x 3/8" Hose Coupling	490-016
3/8" x 3/8" Hose Coupling	490-014
T-Fittings	490-036
4 gun Manifold	500-056
Tip Filter Retainer	520-046
1/4" Mx1/4"F Swivel Union	490-005
1/4" Mx3/8"F Swivel Union	490-032
Retaining Nut Adapter	490-007
High Pressure Fl. Gauge	730-235

Elite E 20
Pump Only – 761-502 220 V Pump Only – 761-238
Complete – 761-500 220 V Complete – 761-240

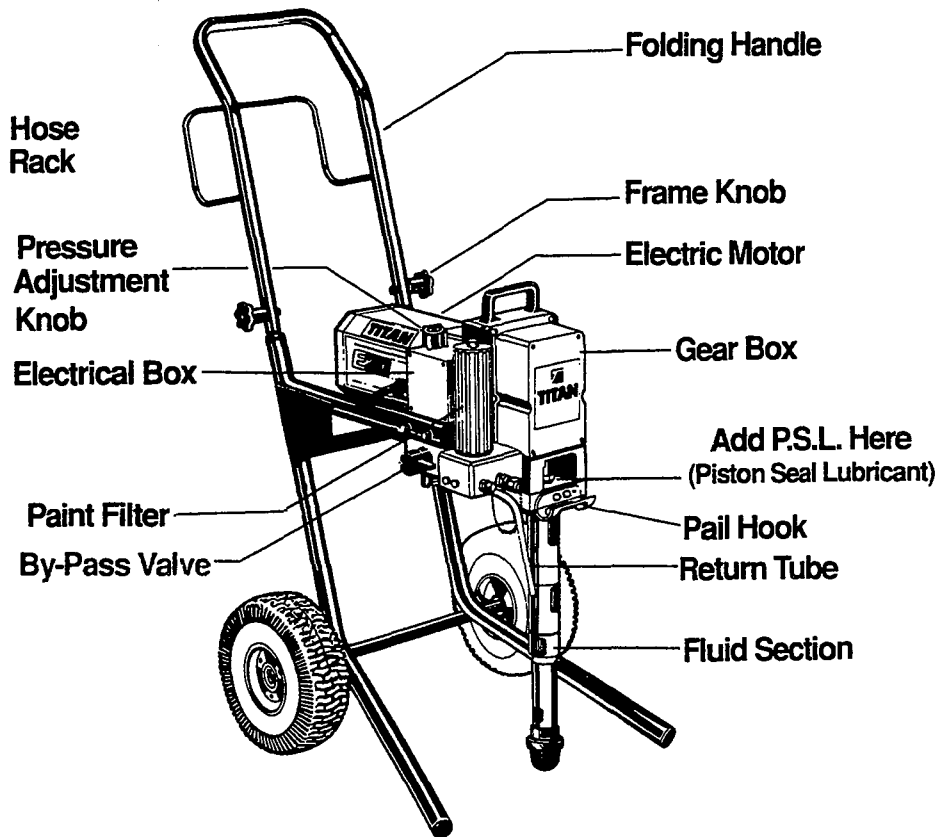

Figure 1

General Repair & Service Notes:

WARNING: Before proceeding, follow the Pressure Relief Procedure outlined on Page 3. Additionally, follow all other warnings to reduce the risk of an injection injury, injury from moving parts or electric shock. Always unplug the sprayer before servicing!

The following tools are needed when repairing this sprayer:

Phillips Screwdriver	3/8" Allen Wrench
Needle Nose Pliers	5/16" Allen Wrench
Adjustable Wrench	1/4" Allen Wrench
Rubber Mallet	3/16" Allen Wrench
Flatblade Screwdriver	1/8" Allen Wrench
1/2" Open End Wrench	

1. Before repairing any part of the sprayer, read the instructions carefully, including all warnings.
2. When disconnecting wires, use needle nose pliers to separate mating connectors.

NOTE: Repacking Kit 761-175 is available. All Parts included in the Kit are marked with a "√" in parts list chart on page 22. For Best results use all parts supplied in the Repacking Kit.

CAUTION: Never pull on a wire to disconnect it. Pulling on a wire could loosen the connector from the wire.

3. Test your repair before regular operation of the sprayer to be sure that the problem is corrected. If the sprayer does not operate properly, review the repair procedure to determine if everything was done correctly. Refer to the Troubleshooting Charts to help identify other possible problems.
4. Make certain that the service area is well ventilated in case solvents are used during cleaning. Always wear protective eyewear while servicing. Additional protective equipment may be required depending on the type of cleaning solvent. Always contact the supplier of solvents for recommendations.
5. If you have any further questions concerning your TITAN Airless Sprayer, call TITAN Customer Service Department at 1-800-526-5362.

MODEL #	SERIAL #	DATE PURCHASED	COMPANY NAME
---------	----------	----------------	--------------

Titan Tool is in the business of designing and manufacturing spray systems and accessories that make today's Painting Professional become more efficient and profitable. We feel that if you accurately track the maintenance of your equipment on this chart it will improve the performance of this valuable tool to help you get the most out of your investment.

The chart is easy to follow and to use. The Maintenance Schedule allows for the recording of all your service work and will help you make sure your unit is always running at peak performance.

Make sure to fill in the boxes at the top of this record with the model number, serial number, date purchased and your company name. This information will be needed to validate your warranty.

Maintenance Schedule

Check Piston Seal Lubricant Level WEEKLY.

G 55 (Gas Engine Models)

Change Engine Oil Every 50 Hours (G-55)	Date	Date	Date	Date	Date	Date	Date	Date	Date	Date

Clean Air Filter Daily

It is extremely important to clean the air filter daily. Consult the Honda Engine Manual supplied with your unit for proper cleaning instructions.

Air Filter Replaced	Date	Date	Date	Date	Date	Date	Date	Date	Date	Date

E 20 (Electric Motor Models)

Check Motor Brushes Every 200 Hours	Date	Date	Date	Date	Date	Date	Date	Date	Date	Date

Service Record

Date	Service Center	Service Performed	Warranty Service/Repair
Months in Service	Cost of Repair		<input type="checkbox"/> Yes <input type="checkbox"/> No
Date	Service Center	Service Performed	Warranty Service/Repair
Months in Service	Cost of Repair		<input type="checkbox"/> Yes <input type="checkbox"/> No
Date	Service Center	Service Performed	Warranty Service/Repair
Months in Service	Cost of Repair		<input type="checkbox"/> Yes <input type="checkbox"/> No
Date	Service Center	Service Performed	Warranty Service/Repair
Months in Service	Cost of Repair		<input type="checkbox"/> Yes <input type="checkbox"/> No
Date	Service Center	Service Performed	Warranty Service/Repair
Months in Service	Cost of Repair		<input type="checkbox"/> Yes <input type="checkbox"/> No

May Be Copied For Field Use

DO NOT USE EQUIPMENT BEFORE READING THIS SECTION

**WARNING
HIGH PRESSURE SPRAY
CAN CAUSE SERIOUS INJURY.**

Maximum Working Pressure 2750 psi, 190 BAR

An airless spray gun requires that fluid be introduced to it at very high pressure. Fluids under high pressure, from spray or leaks, can penetrate the skin and inject substantial quantities of toxic fluid into the body. If not promptly and properly treated, the injury can cause tissue death or gangrene and may result in serious, permanent disability or amputation of the wounded part. Therefore, extreme caution must be exercised when using any airless spray equipment. **IF YOU ARE INJECTED, SEE A PHYSICIAN IMMEDIATELY. DO NOT TREAT AS A SIMPLE CUT!**

NOTE TO PHYSICIAN: Injection into the skin is a serious, traumatic injury. It is important to treat the injury surgically as soon as possible. Do not delay treatment to research toxicity. Toxicity is a concern with some exotic coatings injected directly into the blood stream. Consultation with a plastic surgeon or a reconstructive hand surgeon may be advised.

- 1) Handle the spray gun carefully. **NEVER** point the gun at yourself or anyone else. **NEVER** permit any part of your body to come in contact with the fluid stream of either the gun or any hose leak. **ALWAYS** keep the gun trigger safety lever in a locked position when not spraying. **ALWAYS** use a tip safety guard.
- 2) **NEVER** attempt to force the flow of fluid backward through the gun with your finger, hand or hand-held object against the gun nozzle. This is **NOT AN AIR SPRAY GUN**.
- 3) **NEVER** attempt to remove tip, disassemble or repair equipment without first doing the following:

PRESSURE RELEASE PROCEDURE

- A. Set trigger safety in a locked position.
- B. Shut off pump and unplug electrical cord.
- C. Release fluid pressure from entire system and trigger gun.
- D. Reset trigger safety in a locked position.

- 4) Before flushing system, always remove spray tip and adjust fluid pressure to lowest possible setting.
- 5) Tighten all fluid connections before each use. **NEVER** exceed 2750 psi with this unit. Make sure that all accessory hoses, connections, swivels and so forth can withstand the high pressures which develop. **NEVER** exceed the pressure rating of any component in the system.
- 6) **WARNING:** The paint hose can develop leaks from wear, kinking, abuse, etc. A leak is capable of injecting fluid into the skin, therefore the paint hose should be inspected before each use. **NEVER** attempt to plug a hose with any part of your body, adhesive tape or any other makeshift device. Do not attempt to repair a spray hose, instead replace it with a new grounded hose. Use only with hoses that have spring guards. **NEVER** use less than 50' of hose with this unit.
- 7) Be sure that the airless equipment being used and the object being sprayed are properly grounded to prevent static discharge or sparks which could cause fire or explosion. **WARNING: ALWAYS** hold the gun against metal container when flushing system with tip removed, to prevent static discharge.
- 8) **ALWAYS** keep the working area around the pump well ventilated. Additionally, the pump itself should be a minimum of 25' from the spray area. If these instructions are not followed there is the possibility of fire or explosion with certain materials. **ALWAYS** follow the coating or solvent manufacturers safety precautions and warnings. Never spray flammable material near open flames, pilot lights or any source of ignition.
- 9) **ALWAYS** wear spray masks and protective eyewear while spraying. Additional personal protective equipment may be required depending on the type of material being sprayed and conditions of ventilation. Always contact supplier of material for recommendation.
- 10) Keep all extension poles clear of electrical wires.
- 11) **NEVER** alter or modify any part of this equipment; doing so could cause it to malfunction.
- 12) **NEVER** leave equipment unattended. Keep away from children or anyone not familiar with the operation of airless equipment.

NO USE EL EQUIPO ANTES DE LEER ESTA SECCION

AVISO

LA ROCIADURA A PRESION ALTA PUEDE CAUSAR LESION GRAVE.

Presión de Trabajo Máxima 2750 libras por pulgada cuadrada (psi)190 BAR

Una pistola rociadora sin aire requiere que se le introduzca fluido a presión muy alta. Los fluidos bajo presión alta, o de la rociadora o de las fugas, pueden penetrar en la piel e inyectar en el cuerpo cantidades considerables de fluido tóxico. Si no se atiende pronta y apropiadamente, la lesión puede causar muerte del tejido o gangrena, y puede resultar en la inhabilidad seria y permanente o en la amputación de la parte dañada. Por eso, hay que emplear precauciones estrictas al usar cualquier equipo de rociadura sin aire. SI USTED SE INYECTA, CONSULTE INMEDIATAMENTE AL MEDICO. ¡NO TRATE LA HERIDA COMO SI FUERA UNA MERA CORTADURA!

NOTA PARA EL MEDICO: La inyección en la piel es una herida seria y traumática. Es importante tratar la herida quirúrgicamente lo más pronto posible. No demore el tratamiento para averiguar la toxicidad. La toxicidad es un asunto importante en cuanto a algunos revestimientos exóticos inyectados directamente en el caudal sanguíneo. Puede que sea necesaria la consultación con un cirujano plástico o un cirujano especialista en la reconstrucción de la mano.

- 1) Maneje la pistola de rocío con cuidado. JAMÁS apunte la pistola hacia Ud. u otra persona. NUNCA permita que parte alguna de su cuerpo se ponga en contacto con el chorro de líquido de la pistola o de alguna fuga de la manguera. SIEMPRE mantenga trabado el seguro de la pistola mientras no esté rociando. SIEMPRE utilice una virola de seguridad.
- 2) JAMÁS intente forzar el flujo del líquido hacia atrás por la pistola con el dedo, la mano o un objeto mantenido contra la boquilla de la pistola, ya que ésta no se trata de una PISTOLA DE ROCIO NEUMATICA.
- 3) JAMÁS intente quitar la boquilla ni desarmar o reparar el equipo sin haber cumplido antes con los pasos siguientes:

PROCEDIMIENTO DE DESCOMPRESIÓN

- A. Coloque el seguro en posición trabada.
- B. Apague la bomba y desconecte también la cuerda eléctrica.
- C. Descargue la presión del líquido en todo el sistema y la pistola.
- D. Vuelva a trabar el seguro.

- 4) Antes de enjuagar el sistema, siempre quite la boquilla de rocío y ajuste la presión del líquido al valor más bajo posible.
- 5) Ajuste todas las conexiones antes de cada uso. JAMÁS exceda 2750 libras por pulgada cuadrada con esta unidad. Asegúrese de que todas las mangueras, conexiones, articulaciones giratorias y demás elementos accesorios estén en condiciones de tolerar las altas presiones desarrolladas. JAMÁS exceda la capacidad nominal de cualquier componente del sistema.
- 6) **ADVERTENCIA:** La manguera puede desarrollar fugas como resultado del desgaste, retorcimiento, abuso, etc. Las fugas son capaces de inyectar líquido a través de la piel, por lo que la manguera de pintura debe ser inspeccionada antes de cada uso. JAMÁS intente obturar la manguera con una parte de su cuerpo o con tela adhesiva o cualquier otro expediente provisorio. Evite intentar reparar una manguera de rocío; en cambio reemplácela con una manguera nueva conectada a tierra. Utilice solamente mangueras con guardas de resorte. JAMÁS use con esta unidad una manguera de menos de 50 pies.
- 7) Asegúrese que el equipo sin aire que este empleando y el objeto que se intenta rociar esten correctamente puestos a tierra para evitar descarga estática o chispas que podrian producir fuego o explosión. **ADVERTENCIA:** Sostener SIEMPRE la pistola contra el receptaculo de metal al inundar el sistema con la boquilla desprendida, para evitar descarga estática.
- 8) SIEMPRE mantenga el lugar de trabajo vecino a la bomba bien ventilado. Además, la bomba en sí debe estar ubicada a no menos de 25 pies de la operación de rocío. Si no se obedecen estas instrucciones hay riesgo de incendio o explosión con ciertos materiales. SIEMPRE obedezca las precauciones advertencias de los fabricantes de revestimientos y solventes. Nunca roce material inflamable cerca a algo en llamas o flameante, encendedores mecheros o cualquier fuente de encendido.
- 9) SIEMPRE use máscaras apropiadas y anteojos de protección durante la operación de rocío. Según el tipo de material usado y las condiciones de ventilación puede ser necesario usar equipo personal protector adicional. En todo caso obtenga las recomendaciones del fabricante del material.
- 10) Mantenga todas las varas de extensión fuera del alcance de cables eléctricos.
- 11) JAMÁS altere o modifique parte alguna de este equipo, ya que ello puede causar deficiencias de funcionamiento.
- 12) JAMÁS deje al equipo solo. Manténgalo fuera del alcance de los niños y de cualquier persona no familiarizada con la operación de equipo no neumático.

NE PAS UTILISER LE MATERIEL AVANT D'AVOIR LU CETTE SECTION

ATTENTION!

LES PULVERISATEURS A HAUTE PRESSION PEUVENT PROVOQUER DE SERIEUSES LESIONS

Pression de travail maximale: 2750 psi – 190 BAR

Le liquide introduit dans un pistolet pulvérisateur sans air doit l'être à pression extrêmement élevée. Les liquides à haute pression, en provenance du pulvérisateur ou d'une fuite quelconque, sont capables de pénétrer la peau et d'injecter d'importantes quantités de liquide toxique dans l'organisme. Si elle n'est pas traitée promptement et avec toute l'attention voulue, une blessure causée de la sorte peut provoquer la nécrose des tissus ou gangrène et donner lieu à de sérieux handicaps permanents, voire à l'amputation du membre atteint. Une prudence extrême s'impose donc lors de l'utilisation de matériel de pulvérisation sans air. **EN CAS D'INJECTION, CONSULTEZ UN MEDECIN IMMEDIATEMENT. NE TRAITEZ PAS LA BLESSURE COMME S'IL S'AGISSAIT D'UNE SIMPLE COUPURE!**

REMARQUE A L'INTENTION DU MEDECIN : Une injection pénétrant la peau constitue une lésion traumatique grave qu'il est important de traiter chirurgicalement aussitôt que possible. Ne perdez pas de temps à rechercher la toxicité de l'injection. Il s'agit là d'un risque à envisager en cas d'injection directe dans le circuit sanguin de certains revêtements exotiques. La consultation d'un chirurgien plasticien ou d'un spécialiste de la chirurgie reconstructive de la main peut être recommandable.

- 1) Maniez le pistolet avec soin. N'en dirigez jamais la buse vers aucune partie de votre corps ou vers aucune autre personne. Ne laissez jamais aucune partie de votre corps entrer en contact avec le flux de liquide s'échappant du pistolet ou d'une fuite quelconque au niveau du tuyau. Verrouillez toujours le levier de sûreté de la détente lorsque vous n'êtes pas occupé à pulvériser. *Veillez à toujours utiliser un dispositif de sûreté à la buse du pistolet.*
- 2) N'essayez jamais d'enlever la buse, de démonter ou de réparer l'appareil avant d'avoir accompli la procédure suivante:

PROCEDURE DE RELACHEMENT DE PRESSION

- A. Verrouillez la sûreté de la détente.
- B. Eteignez la pompe et débranchez le cordon électrique.
- C. Relâchez la pression dans l'ensemble du système et appuyez sur la détente du pistolet.
- D. Re-verrouillez la sûreté de la détente.

- 3) Avant de procéder au rinçage du système, enlevez toujours la buse de pulvérisation et réglez la pression au niveau le plus faible possible.
- 4) N'utilisez aucune pièce de matériel sans air avec une pompe non équipée d'une soupape de surpression.
- 5) N'essayez jamais de refouler le flux de liquide dans le pistolet au moyen de votre doigt, de votre main ou d'un objet maintenu contre la buse du pistolet. **CET APPAREIL N'EST PAS UN PISTOLET PULVERISATEUR A AIR.**
- 6) **ATTENTION:** Des fuites risquent de se produire le long du tuyau de peinture sous l'effet de l'usure, des torsions, des rudes traitements, etc. auxquels il est éventuellement soumis. Les injections de liquide dans la peau sont possibles par la voie de telles fuites. Il est donc important d'inspecter le tuyau avant chaque usage. N'essayez jamais d'obturer une fuite à l'aide de votre doigt ou de tout autre membre de votre corps, de ruban adhésif ou de tout autre moyen de fortune. N'essayez pas non plus de réparer un tuyau de pulvérisation; remplacez-le plutôt par un nouveau tuyau mis à la terre. Veillez à n'utiliser que les tuyaux munis de dispositifs de sécurité à ressort.
- 7) Serrez bien tous les raccords du système hydrodynamique avant chaque emploi. Ne dépassez jamais, avec cet appareil, une pression de 2750 psi. Assurez-vous que tous les tuyaux accessoires, raccords, articulations, etc. sont bien capables de résister aux hautes pressions prévues. Ne dépassez jamais la capacité de pression nominale d'aucun composant du système.
- 8) Assurez-vous que le matériel sans air utilisé et que l'objet à peindre sont adéquatement mis à la terre, de façon à éviter toute décharge d'électricité statique ou toute étincelle susceptible de provoquer un incendie ou une explosion. Tenez toujours le pistolet contre un récipient en métal lors du rinçage du système, après en avoir ôté la buse. Ne jamais vaporiser de substances inflammables à proximité de flammes nues, lampes témoin ni d'aucune source d'allumage.
- 9) Le moteur électrique de cet appareil n'est pas protégé contre les explosions. Il est donc essentiel d'assurer une bonne ventilation de la zone de travail et des alentours de la pompe. Il est également important de maintenir la pompe à une distance minimale de 25 pieds (7,5 m) de la zone de pulvérisation. Certains matériaux présentent, à défaut de suivre ces consignes, un risque d'incendie ou d'explosion. Suivez toujours les précautions et avertissements du fabricant de chaque solvant ou revêtement utilisé.
- 10) Portez toujours un masque et des lunettes de protection lors de vos travaux de pulvérisation. D'autres articles de protection personnelle peuvent être nécessaires suivant le type de produit pulvérisé et les conditions d'aération. Demandez toujours ses recommandations à votre fournisseur.
- 11) Maintenez toutes les tiges de rallonge à distance des fils électriques.
- 12) Ne laissez jamais le matériel sans surveillance. Gardez-le hors de portée des enfants et de toute personne inexpérimentée quant à l'usage de matériel sans air.

FIRE OR EXPLOSION HAZARD

Static electricity is created by the high velocity of fluid through the pump, hose and tip. If every part of the spray element is not properly grounded, sparking may occur and the system may become hazardous. Sparking may also occur when plugging in or unplugging a power supply cord, or starting a gas engine. Sparks can ignite fumes from solvents or the fluids being sprayed. Always plug the sprayer into an outlet at least 25' away from the spray area. **WARNING: Always flush the unit into a separate metal container with the spray tip removed and the gun held firmly against the side of the container to assure proper grounding and prevent static discharge which could cause serious bodily injury.**

If you experience any static sparking or slight shock while using this equipment stop spraying immediately. Check the entire system for proper grounding. Do not use the system again until the problem has been corrected.

ELECTRIC MOTOR

Although totally enclosed, the electric motors used by TITAN are not explosion proof. Therefore, it is essential to keep the working area around the pump well ventilated. Additionally, the pump itself should be a minimum of 25' from the spray area. **WARNING: Always keep pump outside of any enclosed spray area. Never clean the exterior of the pump with any flammable solvents, while the pump is plugged in or operating.**

GAS ENGINE (Where Applicable)

Always keep pump outside of any enclosed spray area. Keep area around pump well ventilated. Keep all solvents away from engine exhaust. (Never fill the fuel tank while the engine is running or hot. Fuel spilled on a hot surface can ignite and cause a fire.) Always attach ground wire located on rear of engine to a grounded object, i.e. water pipe. NOTE: Refer to engine owners manual for additional safety and service information.

FLUID SECTION

Halogenated Hydrocarbon solvents can cause an explosion when used with aluminum or galvanized components in a closed (pressurizable) fluid system (pumps, heaters, filters, valves, spray guns, tanks, etc.)

The explosion could cause serious injury, death, and/or substantial property damage.

Cleaning agents, coatings, paints, etc., may contain Halogenated Hydrocarbon solvents.

Titan Tool Inc. spray equipment includes aluminum or galvanized components and will be affected by Halogenated Hydrocarbon solvents.

EXPLANATION OF THE HAZARD

There are three key elements to the Halogenated Hydrocarbon (HHC) solvent hazard. These elements are:

1. **The presence of HHC solvents.**
2. **Aluminum or Galvanized Parts.**
3. **Equipment Capable of Withstanding Pressure.**

When all three elements are present, the result can be an extremely violent explosion. The reaction can be sustained with very little aluminum or galvanized metal: any amount of aluminum is too much.

The reaction is unpredictable. Prior use of an HHC solvent without incident (corrosion or explosion) does NOT mean that such use is safe.

PELIGRO DE INCENDIO O EXPLOSION

La alta velocidad del líquido dentro de la bomba y la manguera produce electricidad estática. Si algún componente del equipo de rocío no está conectado a tierra correctamente pueden producirse chispas y el sistema se vuelve peligroso. También pueden producirse chispas al enchufar o desenchufar cables eléctricos o al poner en funcionamiento el motor. Las chispas pueden encender los vapores provenientes de los solventes o de los líquidos rociados. Siempre conecte el rociador a un enchufe ubicado a no menos de 25 pies de distancia del rociador y la zona de rocío. Si ocurren chispas de electricidad estática o si sufre un choque ligero mientras usa el equipo, deje de rociar de inmediato. Verifique que el sistema en su totalidad esté conectado a tierra correctamente. No vuelva a usar el sistema hasta que el problema haya sido resuelto. **ADVERTENCIA: Lavar siempre la unidad por inundación en un recipiente metálico separado con la boca del rociador removida y teniendo la pistola firmemente contra el lado del recipiente para asegurar una puesta a tierra correcta y evitar la descarga estática que podría causar lesión corporal grave.**

MOTOR ELÉCTRICO:

Los motores eléctricos utilizados por TITAN no son a prueba de explosión. Por lo tanto, es esencial mantener el área de trabajo alrededor de la bomba bien ventilada. Además, la bomba misma debe estar a una distancia mínima de 25 pies (7,5 m) del área de rociadura. **ADVERTENCIA: Mantener siempre la bomba fuera de cualquier área de rociadura cerrada. Nunca limpie el exterior de la bomba con solventes inflamables mientras la bomba este conectada o operando.**

MOTOR A GASOLINA: (Where Applicable)

Siempre mantenga la bomba fuera de cualquier zona de rocío cerrada. Mantenga la zona vecina a la bomba bien ventilada. Mantenga todos los solventes lejos del escape del motor. Nunca llene el tanque de combustible cuando el motor esté funcionando o caliente. El combustible derramado sobre una superficie caliente puede encenderse y producir un incendio. El alambre de tierra que está localizado en la parte de atrás del motor, debe estar siempre conectado a un objeto que esté haciendo tierra, por ejemplo, cañería. **NOTA:** Vea el manual de uso del motor para información adicional sobre seguridad y mantenimiento.

SOLVENTES

Los solventes a base de hidrocarburos halogenados pueden provocar explosión cuando se usan con componentes galvanizados o de aluminio en un sistema líquido cerrado (sujeto a presión) (bombas, calefactores, filtros, válvulas, pistolas de rocío, tanques, etc.)

La explosión podría causar lesiones serias e inclusive la muerte, así como daños materiales de consideración. Los líquidos de limpieza, revestimientos, pinturas, etc. pueden contener solventes a base de hidrocarburos halogenados.

El equipo de rocío ofrecido por Titan tiene componentes galvanizados o de aluminio y es afectado por solventes a base de hidrocarburos halogenados.

EXPLICACION DEL RIESGO

Hay tres elementos fundamentales que condicionan el riesgo de los Hidrocarburos Halogenados, a saber:

1. **Presencia de solventes de hidrocarburos halogenados.**
2. **Componentes galvanizados o de aluminio.**
3. **Equipo capaz de tolerar presión.**

Cuando todos estos elementos están presentes, el resultado puede ser una explosión sumamente violenta. La reacción puede tener lugar aun cuando la cantidad de aluminio o metal galvanizado sea muy pequeña: cualquier cantidad de aluminio es excesiva.

La reacción no puede predecirse. El hecho de que un solvente a base de hidrocarburos halogenados haya sido usado anteriormente sin accidentes (corrosión o explosión) NO significa de que dicho uso no es peligroso.

DANGER! RISQUE D'INCENDIE OU D'EXPLOSION

La vitesse du liquide à travers la pompe et le tuyau produit de l'électricité statique. Si tous les éléments du matériel de pulvérisation ne sont pas mis à la terre de manière adéquate, ils risquent de favoriser la production d'étincelles et de rendre le système dangereux. Des étincelles peuvent également se produire lors de branchement ou débranchement d'un cordon de raccordement électrique ou lors de la mise en marche d'un moteur au gaz. De telles étincelles sont susceptibles d'enflammer les vapeurs des solvants ou les liquides pulvérisés. Veillez donc toujours à brancher le pulvérisateur dans une prise située à au moins 25 pieds (7,5 m) du pulvérisateur et de la zone de travail.

Si vous remarquez la formation d'étincelles sous l'effet de la présence d'électricité statique ou que vous ressentez une légère décharge électrique en cours d'utilisation du matériel, arrêtez immédiatement la pulvérisation. Assurez-vous que tous les éléments du système sont bien mis à la terre. Ne remettez pas le système en marche avant d'avoir résolu le problème.

MOTEUR ELECTRIQUE

Les moteurs électriques utilisés par TITAN ne sont pas protégés contre les explosions. Il est donc essentiel d'assurer une bonne ventilation de la zone de travail et des environs de la pompe. Il est également important de maintenir la pompe à une distance minimale de 25 pieds (7,5 m) de la zone de pulvérisation. **ATTENTION:** N'introduisez jamais la pompe dans une zone de pulvérisation fermée. Ne jamais nettoyer l'extérieur de la pompe à l'aide de solvants inflammables pendant que la pompe est branchée ou en marche.

MOTEUR AU GAZ (Where Applicable)

N'introduisez jamais la pompe dans une zone de pulvérisation fermée. Veillez à ce que les environs de la pompe soient toujours bien aérés. Ne placez aucun solvant à proximité du système d'échappement du moteur. (Ne remplissez jamais le réservoir à carburant lorsque le moteur tourne ou s'il est chaud. Renversé sur une surface chaude, le gaz pourrait s'enflammer et provoquer un incendie.) Veillez à toujours bien attacher le fil de terre situé à l'arrière du moteur à un objet mis à la terre (par exemple, une conduite d'eau). **REMARQUE:** Pour plus de détails sur les mesures de sécurité et d'entretien pertinentes, consultez le manuel fourni avec le moteur.

SECTION HYDRODYNAMIQUE

Les solvants à hydrocarbure halogéné sont explosifs en présence de pièces galvanisées ou en aluminium dans un système hydrodynamique fermé (pressurisable) (pompes, radiateurs, filtres, soupapes, pistolets pulvérisateurs, réservoirs, etc.)

L'explosion provoquée pourrait donner lieu à des lésions corporelles graves ou même mortelles et/ou à de sérieux dégâts matériels.

Certains produits d'entretien, revêtements, peintures et autres liquides contiennent des solvants à hydrocarbure halogéné.

Les appareils pulvérisateurs de la Titan` comportent des pièces en aluminium et des composants galvanisés sensibles aux solvants à hydrocarbure halogéné.

EXPLICATION DU RISQUE

Le danger que présentent les solvants à hydrocarbure halogéné se caractérise par trois éléments clés:

1. la présence de solvants à hydrocarbure halogéné,
2. la présence de pièces en aluminium ou galvanisées,
3. un matériel capable de supporter des pressions élevées.

La combinaison de ces trois éléments peut donner lieu à une explosion extrêmement violente. La réaction peut se produire en présence d'une quantité minime d'aluminium ou de métal galvanisé. En fait, la moindre trace d'aluminium en constitue déjà trop.

La réaction est imprévisible. Toute utilisation antérieure de solvant à hydrocarbure halogéné n'ayant donné lieu à aucun incident (corrosion ou explosion) NE CONSTITUE NULLEMENT un signe de sécurité.

HALOGENATED SOLVENTS SOLVENTES HALOGENADOS SOLVANTS HALOGENES

DEFINITION—Any hydrocarbon solvent containing any of the following elements:

DEFINICION—Cualquier solvente a base de hidrocarburos que contenga cualquiera de estos elementos:

DEFINITION— Tout solvant a hydrocarbure contenant l'un des elements suivants:

Fluorine (F) "-fluor-" Chlorine (Cl) "-chloro-" Bromine (Br) "-bromo-" Iodine (I) "-Iodo-"

EXAMPLES (not all-inclusive):

FLUOROCARBON SOLVENTS:

Dichloroflouromethane
Trichloroflouromethane

BROMINATED SOLVENTS:

Ethylene dibromide
Methylene chlorobromide
Methyl bromine

EJEMPLOS (lista parcial):

IODINATED SOLVENTS:

N-butyl iodide
Methyl iodide
Ethyl iodide
Propyl iodide

CHLORINATED SOLVENTS:

Carbon tetrachloride
Chloroform
Ethylene dichloride

EXEMPLES (liste incomplete):

METHYLENE CHLORIDE or
DICHLOROMETHANE

Monochlorobenzene
Orthodichlorobenzene
Perchloroethylene

TRICHLOROETHANE

Trichloroethylene
Monochlorotoluene

Consult your material supplier to determine whether your solvent or coating contains Halogenated Hydrocarbon Solvents.

Consulte la informacion suministrada por su proveedor de materiales para determinar si un solvente o revestimiento contiene Hidrocarburos Halogenados.

Pour determiner si vos solvants ou revetements contiennent des solvants a hydrocarbures halogenes, consultez votre fournisseur.

START UP PROCEDURE

WARNING: High pressure device, thoroughly read and understand the warning section located in the owner's manual and the label on the sprayer.

IMPORTANT: Whenever starting or cleaning this sprayer always reduce engine or motor speed. Additionally, never operate this sprayer for more than 10 seconds without fluid, this can cause unnecessary wear to the packings. **Do not operate dry.**

Step 1: Before you plug in the power cord to the electrical outlet or start the gas engine, do the following.

A. Tighten suction and return hoses, then install a minimum of 50' of nylon airless spray hose and airless gun. Do not install tip yet, or remove if installed. **WARNING:** If you are supplying your own hoses and spray gun, be sure they are electrically grounded and rated for at least 3000 psi (210 bar) working pressure, and that the gun has a tip guard. This is to reduce the risk of serious bodily injury caused by static sparking and fluid injection or overpressurization, causing a component rupture.

B. Preset pressure control by turning the pressure control knob counterclockwise to lowest setting.

C. Place on-off switch in the off position.

D. Be sure to fill the Wet Cup 1/3 full with Piston Seal Lubricant.

Step 2: ELECTRIC MOTOR

- A. Check electrical service, be sure it is 120V 15 amp minimum and that outlet is properly grounded.
- B. Plug electrical cord into a grounded outlet that is at least 25' from the spray area. **Make certain that all extension cords are a three wire, 12 gauge minimum cord with a grounded plug. Never remove third prong or use an adaptor. Never exceed 150' of extension cord.**

Step 3: GAS ENGINE (Where Applicable)

- A. **Check the engine oil level.** Refer to the engine manual supplied, for instructions.
- B. **Fill the gas tank.** Be sure the engine is cool, refueling a hot engine could cause a fire. Close the black fuel shut off lever located under the air cleaner. **Use unleaded high quality gasoline.**
- C. If a secondary hose and gun is not installed be sure the plug is secure.
- D. Place the suction tube into container containing mineral spirits.
- E. Open the fuel shut off lever by pushing it in the direction of the arrow.
- F. Move the throttle lever away from fuel tank.
- G. Close the engine choke lever, located beneath the air cleaner.
- H. Turn the engine switch on. Turn pressure relief prime valve down to prime position.
- I. Pull the starter rope, holding the frame with one hand, pull the rope rapidly and firmly. Continue to hold the rope as you let it return. Pull and return rope until engine starts.

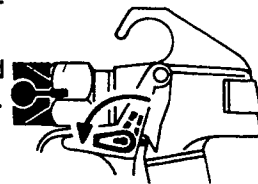

Lock position

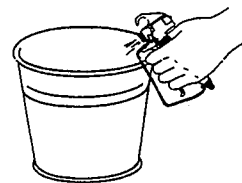

Remove Tip and Safety Guard when flushing

- Step 4:** Flush oil out of new paint pump: Oil is used by the factory for testing and protection. It is necessary to flush out with mineral spirits before you begin to spray.
 - A. Pour 1/2 gallon mineral spirits into a metal container and insert syphon and return tube.
 - B. Turn pressure relief prime valve down to prime position and turn unit on. Increase pressure slightly. Let solvent cycle for approximately 30 seconds. Then tilt syphon tube above container and let the sprayer pump itself dry. Then turn unit off. If you are going to use water based paints, repeat procedure using water.
- Step 5:** Prepare the paint according to manufacturer's recommendations. Remove any skin that may have formed and stir. Strain the paint through a fine nylon mesh bag to remove particles that could clog spray tip.
- Step 6:** Place syphon and return tubes into paint container. Turn pressure relief priming knob, located on side of pump, down for priming.
- Step 7:** Turn sprayer on and turn up pressure slightly. Let circulate on prime until no bubbles filter up through the paint.
- Step 8:** Hold gun firmly against a metal container, disengage trigger lock and trigger gun against side of container. Then, while gun is triggered, turn the pressure relief valve to the spray position. Keep the gun triggered until all the air is forced out of the system and the paint flows freely. Release the trigger and engage gun safety lock, set gun down while unit pressurizes.
- Step 9:** Check for leaks. If any leaks occur, follow the proper pressure relief procedure before tightening.
- Step 10:** Turn off sprayer and relieve pressure by turning pressure relief prime knob to prime.
- Step 11:** With gun trigger lock engaged, install tip and guard as instructed in separate tip or gun manual.
- Step 12:** Turn sprayer on and rotate the pressure relief prime valve to the spray position.
- Step 13:** Test on cardboard to check spray pattern. Adjust pressure just until the spray from gun is completely atomized.

CLEANING PROCEDURE

WARNING: High pressure device, follow all safety warnings located on sprayer and in the owner's manual. **Always clean using low pressure, with the spray tip removed. Always flush into a separate metal container away from the sprayer. Never clean the exterior of the pump while the pump is plugged in or operating.**

- Step 1:** Engage trigger safety lock on gun.
- Step 2:** Turn off pump and release fluid pressure, by turning the pressure relief prime valve located on the side of pump down.
- Step 3:** Remove tip and let soak clean, in a small container of solvents or water. Adjust fluid pressure to lowest possible setting.

- Step 4: Turn the pump on. Tilt syphon tube above paint container allowing the sprayer to pump itself dry through the return tube.
- Step 5: Have container of hot soapy water if spraying latex (or suitable solvent for oil base paints,) available. Do not clean with mineral spirits if using latex paint, this will make jelly.
- Step 6: Place syphon tube into container with hot soapy water or solvents. Let circulate for 2-3 minutes, then turn unit off.
- Step 7: To save paint still in spray hose, turn prime valve up to spray position, then carefully trigger gun into and against side of metal paint container. Be careful of splashing. When cleaning solution appears, shut off gun and place gun in a separate metal container. Repeat process if spraying with two guns.
- Step 8: Trigger gun and let cleaning solution circulate for approx. 2-3 minutes, then turn unit off.
- Step 9: Turn prime valve down and remove suction tube from cleaning container, turn unit on and allow sprayer to pump dry.
- Step 10: Take a clean container of water or solvent and using low pressure pump through system until clear. If cleaning with water, pump a small amount of mineral spirits or TTI LS-10 solution through pump. This will protect against corrosion.
- Step 11: Take suction tube out of container and let sprayer run itself dry.
- Step 12: Check filter on pump and gun. Clean or replace.
- Step 13: Remove spray tip from solvent, clean with a soft bristle brush and store in a dry place.

FLUSHING SPECIFICATIONS

1. **New Sprayer:** Oil is used by the factory for testing and protection. It is necessary to flush unit before spraying.
 - A. If spraying water-base paint, flush with mineral spirits followed by water.
 - B. If spraying oil-base paint, flush with mineral spirits only.
2. **Changing from water-base to oil-base:** Flush with water then mineral spirits.
3. **Changing from oil-base to water-base:** Flush with mineral spirits then water.
4. **Changing colors:** Flush with a compatible solvent such as water or mineral spirits.
5. **Storage:** To assure proper performance and long life, always clean the sprayer thoroughly before storing.
 - A. **Water-Base Paint:** Flush with water, then mineral spirits and leave the pump, gun and hose filled with mineral spirits. Shut-off and unplug the sprayer and turn pressure relief prime valve to prime to relieve pressure. Return prime valve to spray position.
 - B. **Oil-Base Paint:** Flush with mineral spirits. Shut-off and unplug the sprayer, turn the pressure relief prime valve to prime to relieve pressure and leave open. Return prime valve to spray position.
6. **Start-Up After Storage:**
 - A. **Water-Base Paint:** Flush out mineral spirits with water.
 - B. **Oil-Base Paint:** Flush out the mineral spirits with the material to be sprayed.

Always dispose of mineral spirits in a proper way.

APPLICATION TECHNIQUES

The following techniques, if followed, will assure professional painting results.

Hold the gun perpendicular to the surface and always at equal distance from the surface. Depending on the type of material, surface or desired spray pattern, the gun should be held at a distance of 12 to 14 inches.

Move the gun either across or up and down the surface at a steady rate. Moving the gun at a constant speed conserves material and provides even coverage. The correct spraying speed allows a full wet coat of paint to be applied without runs or sags.

Holding the gun closer to the surface deposits more paint on the surface and produces a narrower spray pattern. Holding the gun farther from the surface produces a thinner coat and wider spray pattern. If runs, sags or excessive paint occur, change to a spray tip with a smaller orifice. Conversely, if there is an insufficient amount of paint on the surface or you desire to spray faster, a larger orifice tip should be selected.

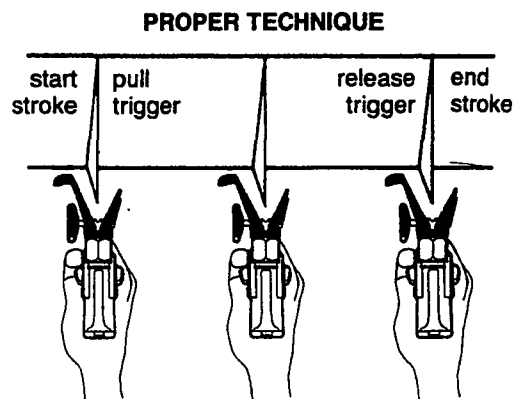

Maintain uniform spray stroke action. Spray alternately from left to right and right to left. Begin movement of the gun before the trigger is pulled.

Proper lapping (overlap of spray pattern) is essential to an even finish. Lap each stroke. If you are spraying horizontally, aim at the bottom edge of the preceding stroke, so as to lap the previous pattern by 50%.

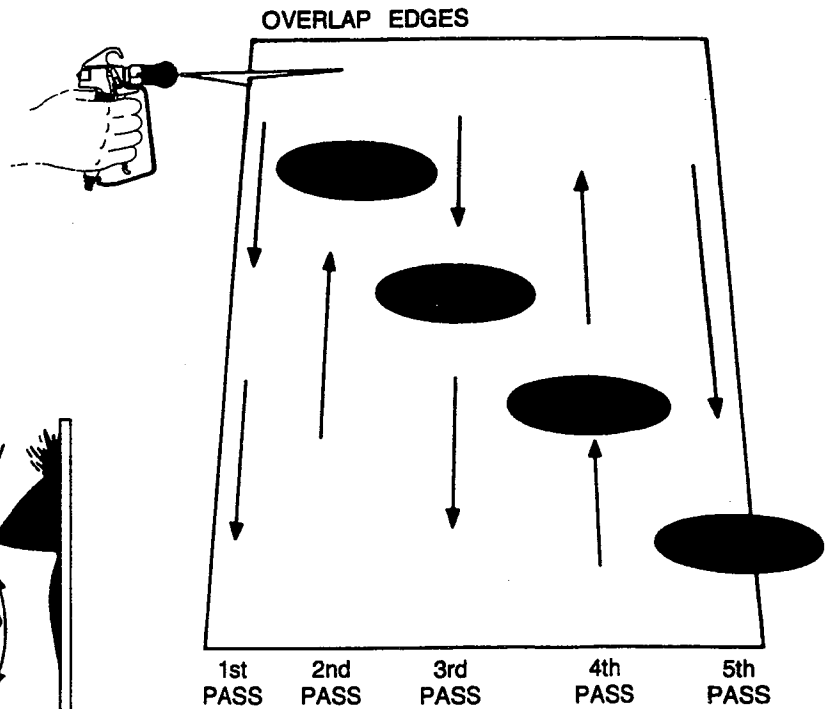

WRONG TECHNIQUE

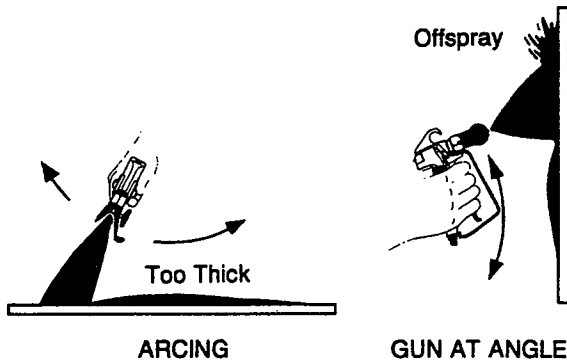

Avoid arcing or holding the gun at an angle. This will result in an uneven finish.

For corners and edges, split the center of the spray pattern on the corner or edge and spray vertically so that both adjoining sections receive approximate even amounts of paint.

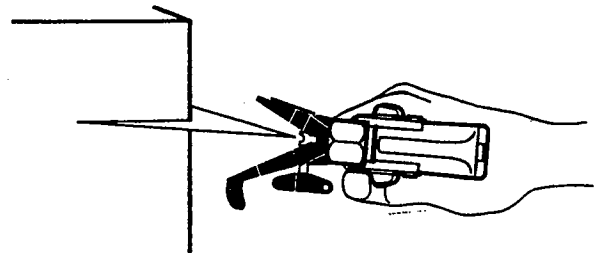

If conditions are windy, angle the spray pattern into the wind to minimize drifting. Work from ground to roof. Do not attempt to spray if wind is excessive.

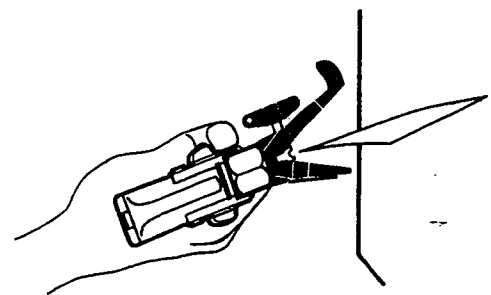

When spraying with a shield, hold it firmly against the surface. Angle the spray gun slightly away from the shield and toward the surface. This will prevent paint from being forced underneath.

Shrubs next to houses should be tied back and covered with a canvas cloth. The cloth should be removed as soon as possible. Titan Gun Extensions are extremely helpful in these situations.

Nearby objects such as automobiles, outdoor furniture, etc., should be moved or covered whenever in the vicinity of a spray job. Be careful of any other surrounding objects that could be damaged by overspray.

AIRLESS TIP SELECTION

Tips are selected by the orifice size and fan width. The proper selection is determined by the fan width required for a specific job and by the orifice size that will supply the desired amount of fluid and accomplish proper atomization. For light viscosity fluids, smaller orifice tips generally are desired. For heavier viscosity materials larger orifice tips are preferred. Please refer to the chart below.

Note: Do not exceed the pump's recommended tip size.

The following chart indicates the most common sizes and the appropriate materials to be sprayed.

.011 - .013	Lacquers & Stains	100 Mesh Filter
.015 - .019	Oil & Latex	60 Mesh Filter
.021 - .026	Heavy Bodied Latex and Blockfillers	30 Mesh Filter

Fan widths measuring 8" to 12" are most preferred because they offer more control while spraying and are less likely to plug.

TROUBLESHOOTING SPRAY PATTERNS

PROBLEM	PROBABLE CAUSE	REMEDY
Tails	<ol style="list-style-type: none"> 1. Inadequate fluid delivery 2. Fluid not atomizing 3. Insufficient velocity 4. Material too cohesive 5. Tip worn past pump capacity 	<ol style="list-style-type: none"> 1. Increase pressure 2. Change to smaller tip 3. Clean gun and pump filters 4. Reduce viscosity 5. Replace
Heavy centered pattern	<ol style="list-style-type: none"> 1. Worn tip 2. Tip may be chipped 	<ol style="list-style-type: none"> 1. Replace 2. Replace
Distorted Pattern	<ol style="list-style-type: none"> 1. Plugged, worn or chipped tip 	<ol style="list-style-type: none"> 1. Clean or replace
Pattern expanding and contracting (Surge)	<ol style="list-style-type: none"> 1. Leak in suction tube 2. Not enough hose 3. Tip too large or worn 	<ol style="list-style-type: none"> 1. Tighten 2. Use a minimum of 50' of ¼" high pressure hose 3. Replace with a new or smaller tip

TROUBLESHOOTING AIRLESS GUN

TROUBLE	PROBABLE CAUSE	REMEDY
Spitting gun	<ol style="list-style-type: none"> 1. Air in system 2. Dirty gun 3. Needle assembly out of adj. 4. Broken or chipped seat 	<ol style="list-style-type: none"> 1. Inspect connections for air leaks 2. Disassemble and clean 3. Inspect and adjust 4. Inspect and replace
Gun will not shut off	<ol style="list-style-type: none"> 1. Worn or broken needle and seat 2. Needle assembly out of adj. 3. Dirty gun 	<ol style="list-style-type: none"> 1. Replace 2. Adjust 3. Clean
Gun does not spray	<ol style="list-style-type: none"> 1. No paint 2. Plugged filter or tip 3. Broken needle in gun 	<ol style="list-style-type: none"> 1. Check fluid supply 2. Clean 3. Replace

TROUBLESHOOTING AIRLESS PUMP

TROUBLE	PROBABLE CAUSE	REMEDY
Electric motor won't run	<ol style="list-style-type: none"> 1. Unit unplugged or circuit fuse blown 2. Pressure setting too low 3. Brushes on motor are worn 4. Electric motor burned out 5. Switch defective 6. Fuse in pump blown 	<ol style="list-style-type: none"> 1. Check 2. Increase 3. Replace 4. Replace 5. Replace 6. Replace
Gas engine won't start (Where Applicable)	<ol style="list-style-type: none"> 1. Engine switch not on 2. Engine oil level low 3. Out of gas 4. Spark plug cable disconnected or bad plug 	<ol style="list-style-type: none"> 1. Turn on 2. Try starting engine, if light on rear glows, add oil 3. Fill 4. Connect or replace
Pump won't prime	<ol style="list-style-type: none"> 1. Air in line 2. Insufficient pressure 3. Clutch worn or damaged (Gas) 	<ol style="list-style-type: none"> 1. Check syphon tube O-ring and/or let paint circulate in prime position 2. Increase pressure 3. Replace.
Insufficient material flow	<ol style="list-style-type: none"> 1. No paint 2. Syphon strainer clogged 3. Pump/gun filter clogged 4. Pump will not prime, material too heavy 5. Engine not tuned properly (Gas) 6. Worn clutch (Gas) 	<ol style="list-style-type: none"> 1. Check supply 2. Clean 3. Clean and replace 4. Thin material 5. Tune engine 6. Service
Pump will not maintain pressure	<ol style="list-style-type: none"> 1. Air leak in system 2. Air leak in syphon tube 3. Inlet valve not seating 4. Worn packings 5. Broken or worn valve seats 6. Worn prime valve 	<ol style="list-style-type: none"> 1. Tighten connections 2. Tighten, check for leaks 3. Service or clean 4. Replace 5. Reverse or replace 6. Replace
Not enough pressure	<ol style="list-style-type: none"> 1. Pressure setting too low 2. Plugged filters 3. Spray tip too big or worn 4. Engine or motor rpm too low (Gas) 	<ol style="list-style-type: none"> 1. Increase 2. Clean or replace 3. Change or replace 4. Increase throttle
Excessive surge at spray gun	<ol style="list-style-type: none"> 1. Wrong type of hose 2. Spray tip too big or worn 3. Excessive pressure 	<ol style="list-style-type: none"> 1. Replace with a minimum 50' grounded nylon braid high pressure hose 2. Change or replace 3. Decrease pressure and engine speed
Paint leaks into oil cup	<ol style="list-style-type: none"> 1. Worn-out packings 	<ol style="list-style-type: none"> 1. Replace

TITAN

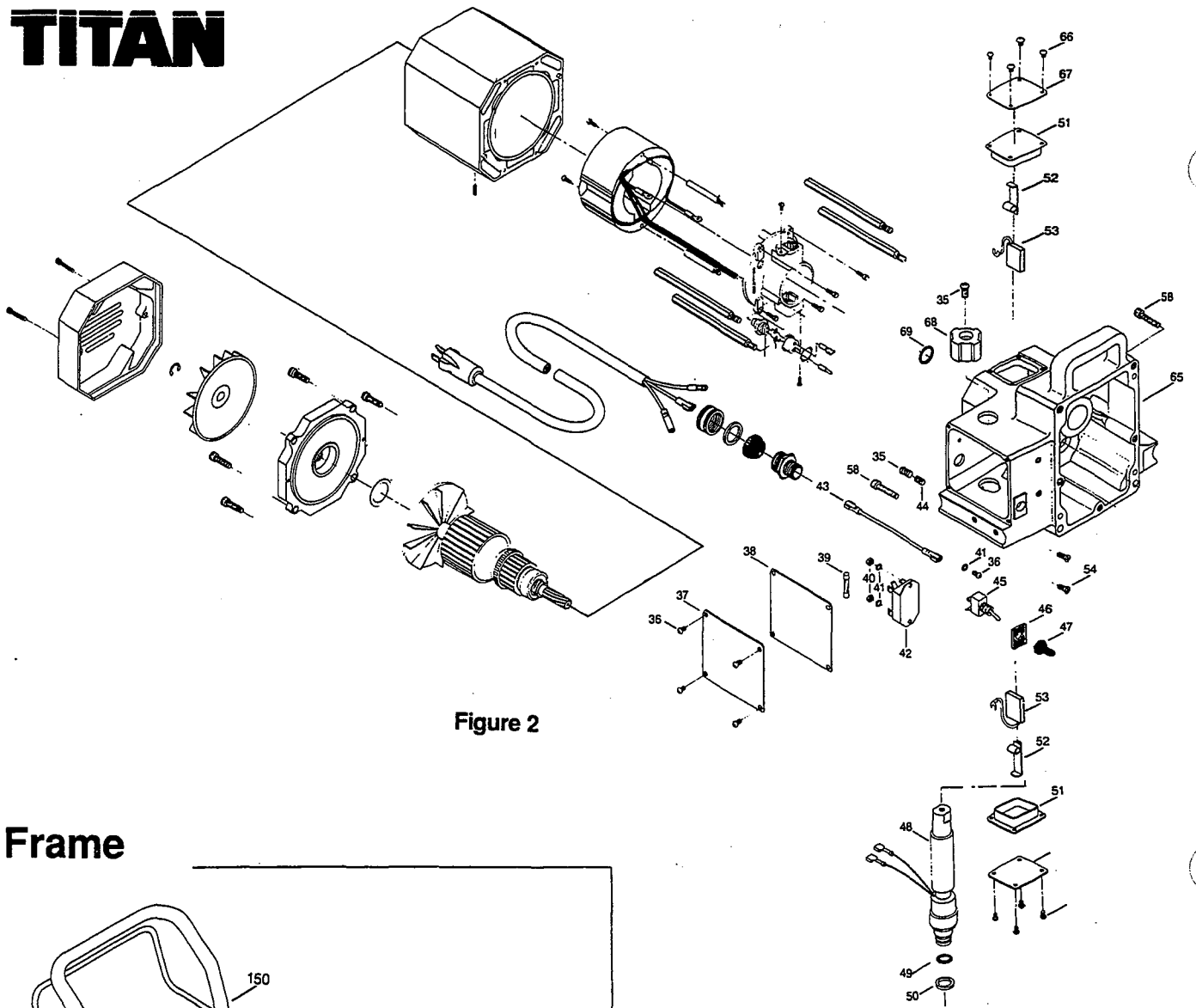

Figure 2

Frame

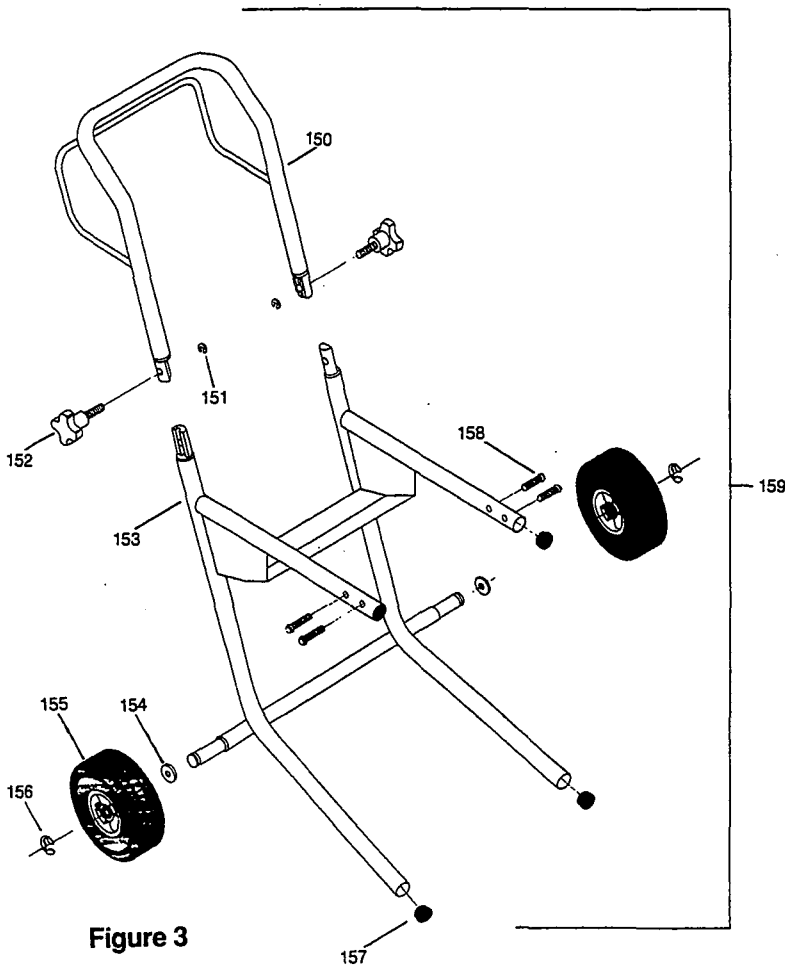

Figure 3

ITEM NO	PART NO	DESCRIPTION	QTY
	150	761-410 Handle	1
	151	761-405 Snap Ring	2
	152	761-412 Knob	2
	153	761-421 Frame Legs (Incl. #157)	1
	154	710-058 Washer	2
	155	710-044 Wheel	2
	156	710-194 Snap Ring	2
	157	710-199 Plug	2
	158	761-178 Screws	4
	159	761-400 Frame Complete (Does not include #158)	1

Replacement Labels

PART NO	DESCRIPTION	QTY
313-125	"TITAN"	2
313-124	"E 20"	2
313-191	"Warning Label, In English	1
313-201	"Warning/Attention Label in French	1
313-130	Front Plate	1

Elite E20

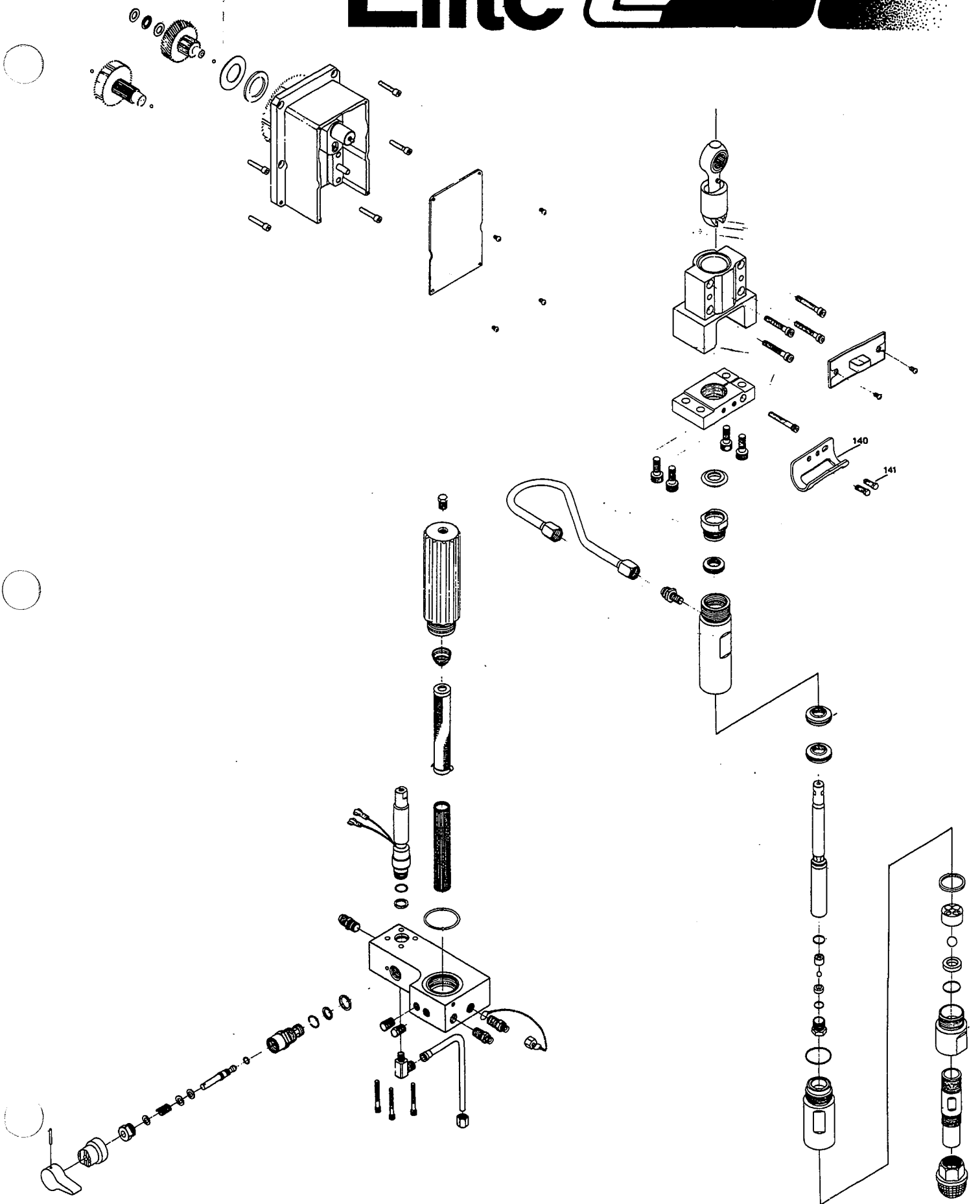

UNITEC Motor Complete

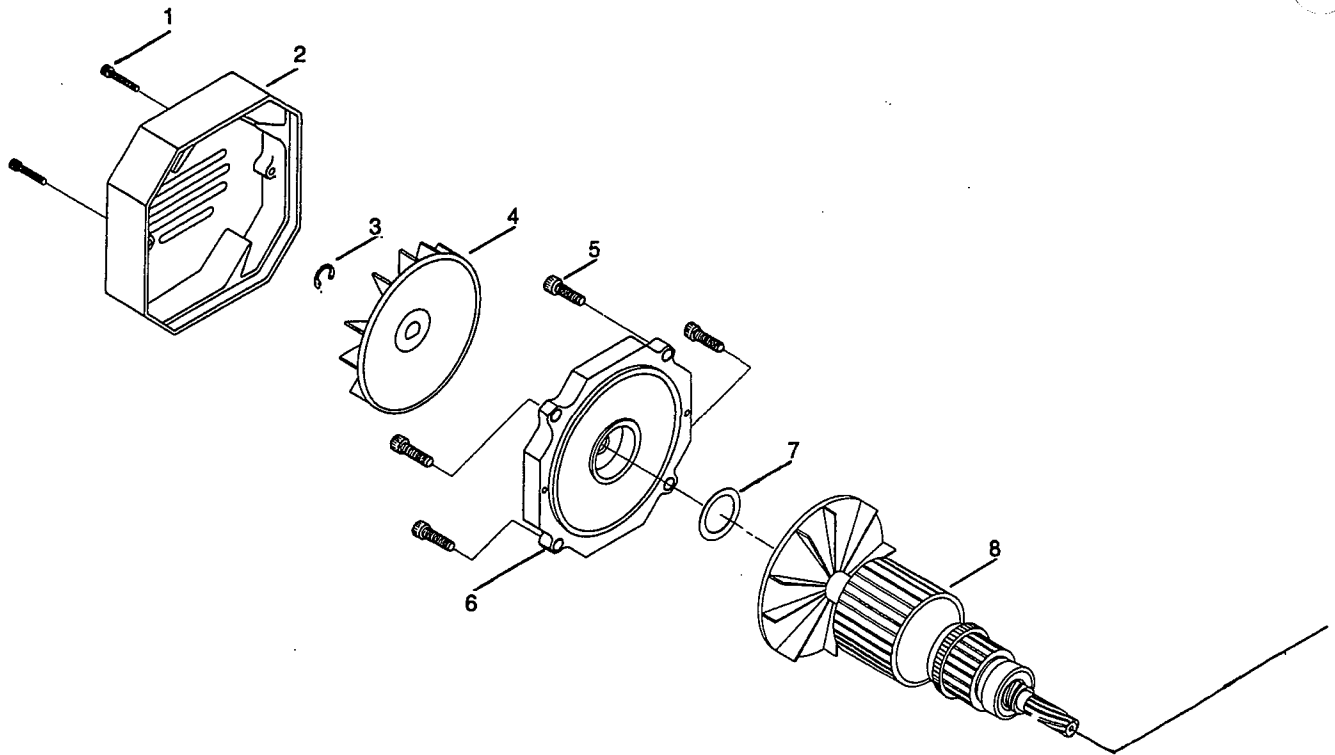

Figure 4

ITEM NO	PART NO	DESCRIPTION	QTY
1	761-023	Screw	2
2	761-027	Rear Cover	1
3	611-405	Snap Ring	1
4	702-040	Outer Fan	1
5	700-681	Screw	4
6	761-028	Rear Motor Housing	1
7	702-047	Wave Washer	1
8	761-302	Armature 120V	1

For 220 Volt Units:

ITEM NO	PART NO	DESCRIPTION	QTY
8	761-231	Armature 220 V	1

Armature Replacement

WARNING: Before proceeding, follow the Pressure Relief Procedure outlined on Page 3. Additionally, follow all other warnings to reduce the risk of an injection injury, injury from moving parts or electric shock, Always unplug the sprayer before servicing!

1. Remove Rear Cover (#2) by taking out screws (#1).
2. Remove Snap Ring (#3).
3. Remove Fan (#4).
4. Remove Rear Motor Housing (#6) by removing screws (#5). **NOTE:** Make sure to remove Wave Washer (#7) which should be on the End Bearing of the Armature.
5. Remove Motor Brushes. Follow Brush replacement procedure. Located on page 20.
6. Remove Armature by gently rocking and pulling Fan from rear of pump.
7. Inspect Armature. If damaged, replace.
8. To replace Armature, reverse steps 1 through 6 here.

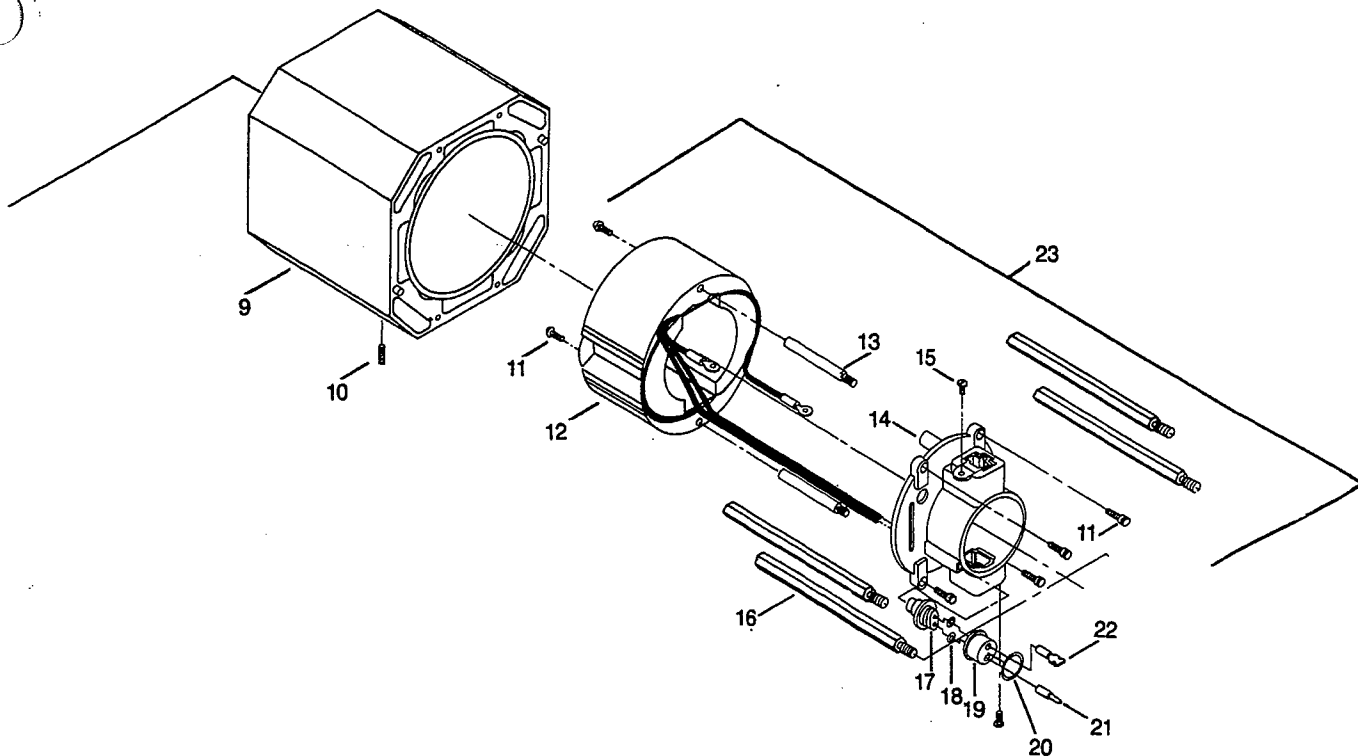

Figure 5

ITEM NO	PART NO	DESCRIPTION	QTY
9	761-045	Outer Housing (Includes #10)	1
10	761-244	Screw	1
11	700-639	Screw	6
12	761-070	Field 120 V (Incl. #21 & 22)	1
13	760-028	Field Screw	2
14	702-072	Brush Holder	1
15	550-201	Screw	2
16	760-027	Mounting Stud	4
17	702-070	Wire Seal Body	1
18	700-721	O-Ring	2
19	702-069	Wire Seal Cap	1
20	700-505	O-Ring	1
21	700-774	Bullet Terminal	1
22	700-772	Push-on Terminal	1
23	761-201	Motor Field Assy. 120V (Does not include #16)	1

For 220 Volt Units:

ITEM NO	PART NO	DESCRIPTION	QTY
12	761-230	Field 220 V (Includes #21 & 22)	1
23	761-237	Field Assembly 220 V	1

Motor Housing Replacement

WARNING: Before proceeding, follow the Pressure Relief Procedure outlined on Page 3. Additionally, follow all other warnings to reduce the risk of an injection injury, injury from moving parts or electric shock, Always unplug the sprayer before servicing!

1. Follow steps 1 through 6 in Armature Replacement.
2. Remove Switch cover plate (#37) and Insulator Plate (#38).
3. Disconnect black wire from Post (#2) of Motor Starter (#42).
4. Disconnect black wire from Motor to white wire from Power Cord.
5. Remove outer Motor Housing (#9).
6. Loosen set screw (#10) and push Motor Field Assembly (#23) out from the back of the outer Motor Housing (#9).
7. Inspect Motor Field Assembly (#23). If damaged, replace.
8. To install Motor Housing, reverse steps 1 through 6 here and steps 1 through 6 of the Armature Replacement.

Gear Box

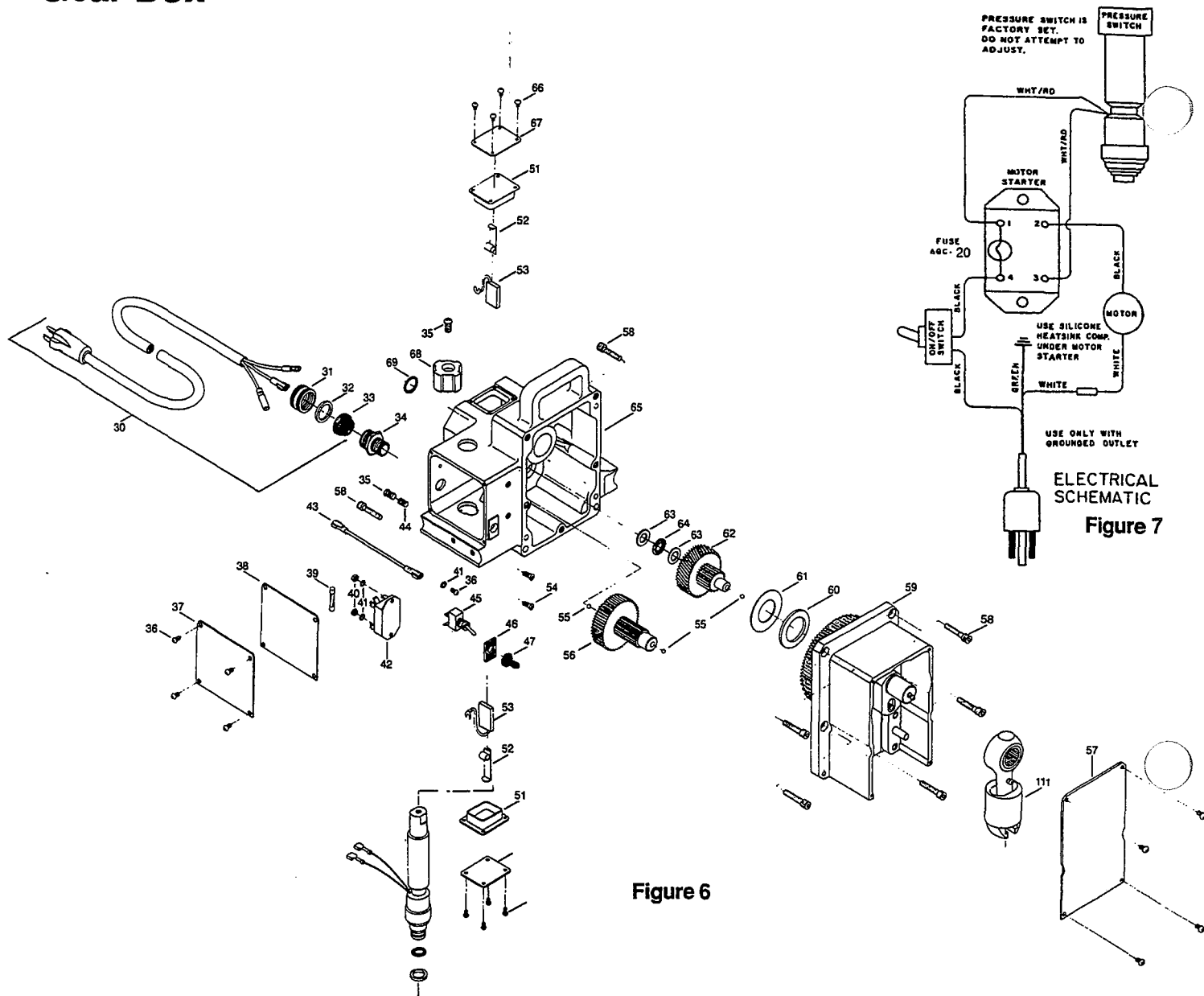

Figure 6

ELECTRICAL SCHEMATIC
Figure 7

ITEM NO	PART NO	DESCRIPTION	QTY	ITEM NO	PART NO	DESCRIPTION	QTY
30	710-150	Power Cord (#31-33)	1	51	702-039	Brush Insulator	2
31	710-157	Cord Grip Nut	1	52	702-067	Brush Spring	2
32	710-156	Cord Grip Washer	1	53	702-066	Brush	2
33	710-155	Rubber Grommet	1	54	700-714	Screw	2
34	710-154	Cord Grip Housing	1	55	761-116	Thrust Ball	3
35	700-784	Screw	2	56	761-083	Output Pinion Gear	1
36	700-653	Screw	9	57	761-193	Front Cover	1
37	761-132	Plate	1	58	761-114	Screw	7
38	761-192	Insulator Plate	1	59	761-100	Crankshaft Housing	1
39	710-050	Fuse 20 Amp	1	60	761-221	Bearing	1
40	700-714	Nut	2	61	700-680	Washer	1
41	700-785	Lock Washer	3	62	761-084	Interior Pinion Gear	1
42	700-657	Motor Starter	1	63	761-102	Washer	2
43	710-064	Wire	1	64	761-101	Bearing	1
44	700-715	Screw	1	65	761-086	Motor Housing (Inc. #69)	1
45	700-646	Toggle Switch	1	66	730-260	Screw	8
46	700-775	On/Off Plate	1	67	702-053	Brush Plate	2
47	700-645	Rubber Boot	1	68	700-771	Knob	1
				69	702-079	O-Ring	1

Gear Repair / Service

WARNING: Before proceeding, follow the Pressure Relief Procedure outlined on Page 3. Additionally, follow all other warnings to reduce the risk of an injection injury, injury from moving parts or electric shock, Always unplug the sprayer before servicing!

1. Remove Cover Plate (#57).
2. Loosen retaining nut on Pipe Assembly (#110) located on page 22.
3. Remove four screws (#113) and pull off Slider Housing and Fluid Section. (See Page 22).
4. Remove seven screws (#58).
5. Remove Crankshaft Housing (#58) by lightly tapping on each corner with a plastic mallet.
6. Remove Output Pinion Gear (#56).
7. Remove Interior Pinion Gear (#62)
8. Examine washers (#63) and Bearings (#64).
9. Before reassembling check the following:
 - a. If installing new Gears make sure that ample grease is applied to Gears and Bearings.
 - b. Check that the Thrust Balls are in place. Because of the amount of grease used in the Bearings where the Thrust Balls are located, they will generally stay in-place.
DO NOT ATTEMPT TO REMOVE.
 - c. Check that the Thrust Bearing Assembly (#63 & #64) is in place.
 - d. Check that the Thrust Bearings (#60) Bronze and (#61) Steel are in place.

On/Off Switch Replacement

WARNING: Before proceeding, follow the Pressure Relief Procedure outlined on Page 3. Additionally, follow all other warnings to reduce the risk of an injection injury, injury from moving parts or electric shock, Always unplug the sprayer before servicing!

1. Remove Switch Cover Plate and screws (#36 & #37). Remove Insulator Plate (#38).
2. Disconnect the two black wires from the On/Off Switch (#45).
3. Remove the rubber boot and plat (#47 & #46) with a wrench.
4. Remove the On/Off Switch (#45).
5. Install a new Switch and reattach plate and rubber boot. Tighten securely.
6. Reconnect the two black wires to the new On/Off Switch.
7. Reinstall Switch Cover Plate and screws, with warning label facing out.

Power Supply Cord Replacement

WARNING: Before proceeding, follow the Pressure Relief Procedure outlined on Page 3. Additionally, follow all other warnings to reduce the risk of an injection injury, injury from moving parts or electric shock, Always unplug the sprayer before servicing!

1. Remove Switch Cover Plate and screws (#36 & #37). Remove insulator Plate (#38).
2. Disconnect the Power Supply Cord (#30) from; a) the On/Off Switch (#45), b) the white wire connected to the motor and, c) the green wire connected to the grounding screw (#36)). Refer to the Electrical Schematic, Figure 5.
3. Loosen the cord grip housing #31 and remove the power cord.
4. Install the new cord in reverse order of disassembly.
5. Install the cover and screws with warning label facing out.

Replacement of Motor Starter

WARNING: Before proceeding, follow the Pressure Relief Procedure outlined on Page 3. Additionally, follow all other warnings to reduce the risk of an injection injury, injury from moving parts or electric shock. Always unplug the sprayer before servicing!

1. Remove Switch Cover Plate and screws (#36 & #37). Remove Insulator Plate (#38).
2. Disconnect wires, a) both white/red wires from the pressure switch, b) the black wire from the motor and, c) the black wire from the On/Off Switch.
3. Remove screws (#54) and washer and nuts (#40 #41).
4. Replace Motor Starter and re-secure with screws, washer and nuts (#40, # 41 and #54). Always use heat sink material on the back of the Motor Starter when installing.
5. Reconnect wires according to Figure 7.
6. Reinstall switch cover and screws, with warning label facing out.

Motor Brush Replacement

WARNING: Before proceeding, follow the Pressure Relief Procedure outlined on Page 3. Additionally, follow all other warnings to reduce the risk of an injection injury, injury from moving parts or electric shock, Always unplug the sprayer before servicing!

1. Remove Brush Plate (#67).
2. Remove Brush Insulator (#51).
3. Remove Brush Spring (#52). **NOTE:** To remove brush spring, push spring down and in for it to release.
4. Back-off screw. Hold Brush Wire and remove Brush.
5. Inspect Motor Brush. If damaged replace.
6. Repeat procedure for other brush.
7. To install Motor Brushes, reverse steps 1 through 6, **NOTE:** Never operate this unit without Brush Insulator and Brush Plate installed.

Filter Block

ITEM NO	PART NO	DESCRIPTION	QTY
48	761-195	Pressure Switch (Incl. #49)	1
49	700-499	O-Ring	1
50	700-483	Gasket	1
80	761-697	Bypass Valve Handle	1
81	761-761	Pin	1
82	761-697	Bypass Cam Base	1
83	761-731	Bypass Valve Retainer	1
84	761-705	Washer	1
85	761-698	Spring	1
86	761-706	Washer	2
87	761-763	Stem (Incl. 88)	1
88	221-008	O-Ring	1
89	761-755	Bypass Housing	1
90	761-721	Back-up Ring	1
91	761-722	O-Ring	1
92	761-537	Gasket	1
93	761-757	Bypass Valve Assembly	1
94	761-160	Connector	1
95	761-456	O-Ring	1
96	761-452	Filter Core	1
97	761-043	Filter Cartridge	1
98	730-083	Spring	1
99	761-451	Filter Housing	1
100	710-069	Plug	3
101	761-422	Filter Block (Incl. #95)	1
102	730-222	Outlet Cup Assembly	1
103	490-006	Fitting	2
104	700-701	Nut	1
105	750-039	Pressure Release Tube	1
106	730-262	Screw	3
107	710-087	Pressure Release Elbow	1
108	761-351	Filter Block Complete (Does not include #48-50, 106)	1

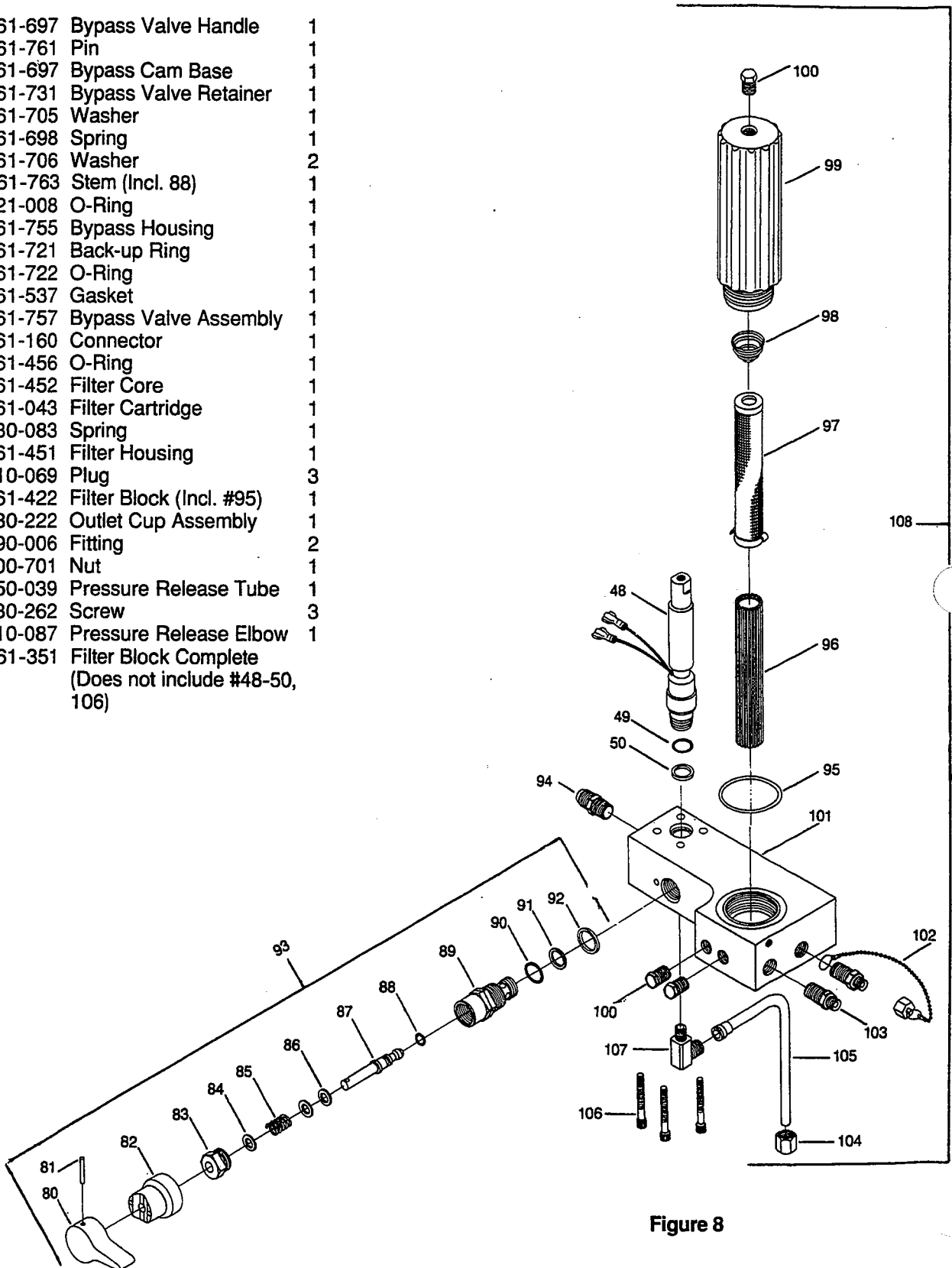

Figure 8

Pressure Switch Replacement

WARNING: Before proceeding, follow the Pressure Relief Procedure outlined on Page 3. Additionally, follow all other warnings to reduce the risk of an injection injury, injury from moving parts or electric shock, Always unplug the sprayer before servicing!

1. Remove the three screws (#106).
2. Loosen the retaining nut on the Tube (#110) from the Connector (#94).
3. Remove the Filter Block Assembly.
4. Remove the Screw (#35) and remove the Knob (#68).
5. Remove the Cover Plate and Insulator (#37 & 38).
6. Disconnect the red wires connecting to the Clutch Starter (#42).
7. Remove the screw (#35) located in the back of the Electrical Box. Insert a 1/8" allen wrench in the hole and back-off the set screw (#44) until the Pressure Switch (#48) is able to slide down through. Feed the electrical wires down at the same time.
8. Insert a new Switch Assembly (#48) into the housing (#65) while carefully guiding the wire not the Switch Box. Using a needle nose pliers reconnect the wire to the Clutch Starter.
9. Making sure that the Switch Assembly is fully inserted, tighten the Set Screw (#44) with a 1/8" allen wrench until the Switch Assembly is secure. Re-attach the Knob (#68).
10. Make sure that the Gasket (#50) is in place. Then install the Filter Block (#101). Secure with three screws (#106, see page 22, Figure 7) and re-attach the retaining nut on the Tube (#110) to the Connector (#94).
11. Install the Cover Plate and Insulator (#37 & 38).
12. The Pressure Switch is Factory Calibrated so no adjustment is required.

Service/Replacement of the Pressure Relief Prime Valve

WARNING: Before proceeding, follow the Pressure Relief Procedure outlined on Page 3. Additionally, follow all other warnings to reduce the risk of an injection injury, injury from moving parts or electric shock, Always unplug the sprayer before servicing!

1. Remove the Groove Pin (#81) from By-Pass Valve Handle (#80). Push out Pin as shown in Figure 6.
2. Remove Handle (#80) and Bypass Cam (#82).
3. Using a wrench, loosen Bypass Housing (#89) and unscrew.
4. Unscrew Bypass Retainer (#83) and remove Bypass Valve Stem (#87).
5. Inspect ball on end of Stem (#87) and O-ring (#88). Clean or replace if worn.
6. When reassembling make sure Washers (#86 & 84) are in place. Screw completed assembly into Filter Block except for items #82, 81 and 80. Tighten securely with wrench.
7. Install Bypass Cam (#82) over Bypass Retainer (#83), lubricate with grease. Line up Groove Pin (#81) on Cam (#82) with hole on Filter Block (#101).
8. Using Groove Pin (#81) line up Stem (#87) with hole on Handle (#80). Secure Handle with Grove Pin (#81).
9. IMPORTANT: If Handle (#80) rotates 360° check Pin on Cam (#82).

Service / Replacement of Filter

WARNING: Before proceeding, follow the Pressure Relief Procedure outlined on Page 3. Additionally, follow all other warnings to reduce the risk of an injection injury, injury from moving parts or electric shock, Always unplug the sprayer before servicing!

PUMP FILTER

1. Unscrew Filter Housing (#99).
2. Remove Filter Cartridge (#97). Clean or replace.
3. Inspect Seal (#95). Clean or replace.
4. Re-attach Filter Housing (#99)

Gun Filter

WARNING: Follow all safety precautions as described in high pressure warning section before proceeding. If your spray gun leaks or spits at the tip when you release the trigger, the needle or seat is dirty, worn or damaged and must be cleaned or replaced.

Replacement or Removal of Filter:

1. First pull down on trigger safety guard and swing away from handle.
2. Unscrew handle from spray head.
3. Unscrew left hand threaded* filter from spray head. (*NOTE: Left handed thread requires turning the filter clockwise to remove.)
4. Screw new or cleaned (†) filter into the head. (To reinstall left hand thread turn counter clockwise.)
5. Reattach handle to head and secure safety trigger guard. (NOTE: If filter breaks off in the head use a small wood screw to remove.)

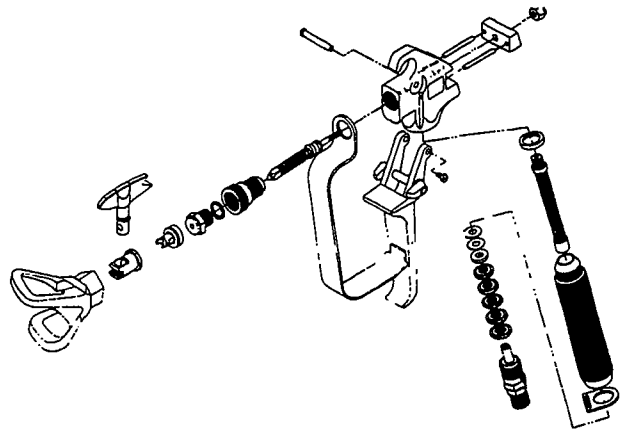

Figure 11 (†)For more detail, part number information and assembly drawings at larger scale, please see the LX-80 Professional Airless Gun Owners Manual (#313-012).

Fluid Section

✓ 761-175 Repacking Kit
(Includes #119, 122, 124, 126, 128,
130, 132, 134, 136)

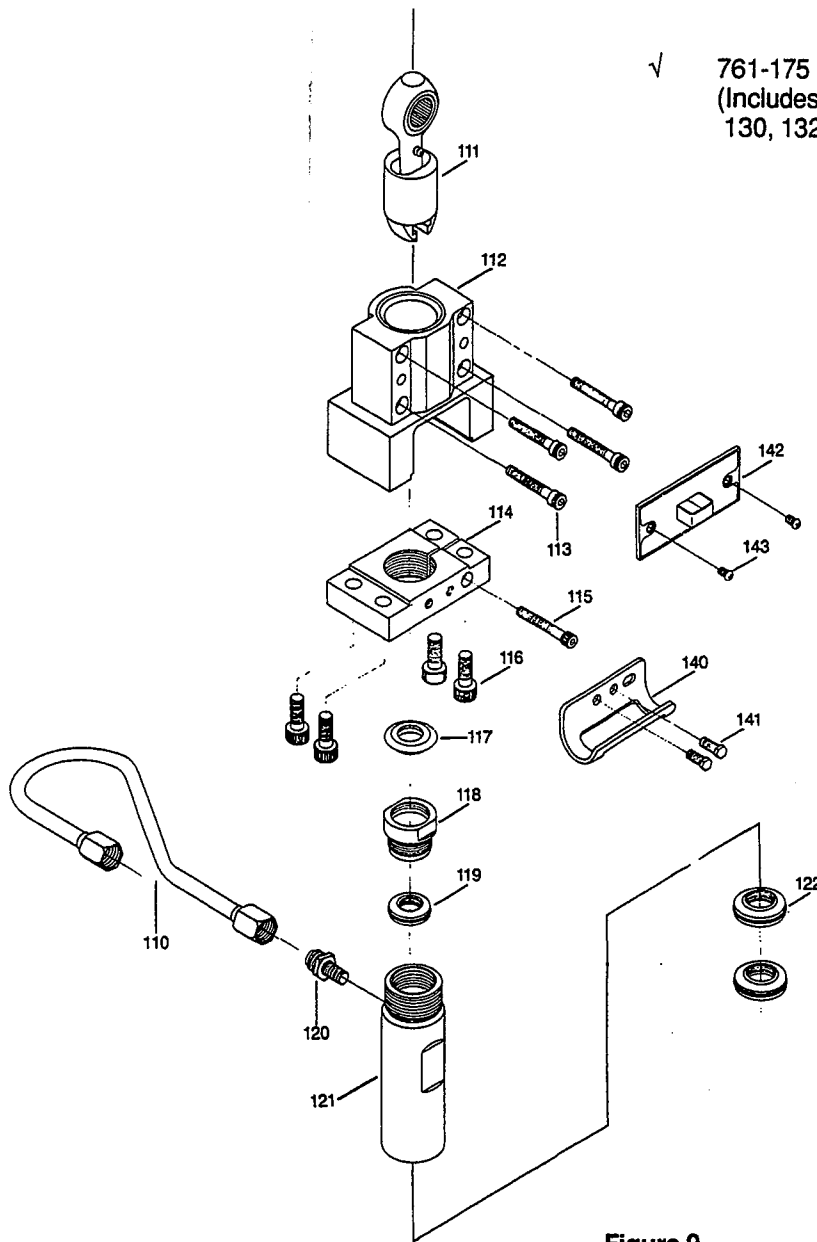

Figure 9

ITEM NO	PART NO	DESCRIPTION	QTY
110	761-152	Pipe Assembly	1
111	761-062	Crank Slide & Connecting Rod	1
112	761-108	Slider Housing	1
113	761-115	Screw	4
114	761-034	Upper Mount	1
115	761-149	Screw	1
116	761-148	Screw	4
117	761-162	Splash Guard	1
118	761-077	Upper Guide	1
119	761-136✓	Upper Seal	1
120	761-159	Connector	1
121	761-118	Upper Housing	1
122	761-138✓	Lower Seal	2
123	761-117	Piston Rod	1
124	761-111✓	Upper Poly Seal	1
125	761-078	Upper Cage (Incl.#124)	1
126	*761-144✓	Upper Ball	1
127	761-079	Upper Seat (Incl. #128)	1
128	761-057✓	O-Ring	1
129	761-073	Retainer	1

ITEM NO	PART NO	DESCRIPTION	QTY
130	761-103✓	O-Ring 1	1
131	761-064	Lower Housing (Incl. #130)	1
132	761-076✓	Lower Poly Seal	1
133	761-075	Lower Cage (Incl. #132)	1
134	*761-145✓	Lower Ball	1
135	761-080	Lower Seat (incl. #136)	1
136	761-058✓	O-Ring	1
137	761-123	Foot Valve Housing	1
138	761-153	Down Tube	1
139	710-046	Inlet Screen	1
140	761-033	Pail Hook	1
141	710-033	Screw	2
142	761-171	Safety Plate	1
*43	730-260	Screw	2

*Recommended Tool Box Parts

761-204 Fluid Section Complete
(Does not include #110, 111, 112, 113,
116, 138-143)

Seat Service and Repair

WARNING: Before proceeding, follow the Pressure Relief Procedure outlined on Page 3. Additionally, follow all other warnings to reduce the risk of an injection injury, injury from moving parts or electric shock, Always unplug the sprayer before servicing!

The design of Titan's Elite Fluid Section allows access to the inlet and outlet balls and seat without completely disassembling the Fluid Section. It is possible that the Balls may not seat properly because of debris stuck in the inlet or outlet seat. Follow the instruction below for access to those areas.

1. Place a wrench on the Foot Valve (#137) and unthread.
2. Clean out all debris. Examine Ball and Seat. If damaged replace. Continue if necessary or re-install.
3. Place a wrench on the Lower Pump Housing (#131) and unthread.
4. Place a wrench on the Retainer (#129) and unthread.
5. Clean out all debris. Examine Ball and Seat. If damaged replace.
6. Reassemble and test unit. Should unit not perform properly consult the Trouble Shooting Guides on pages 13 & 14 of this manual or continue with the Repair and Packing Replacement instructions below.

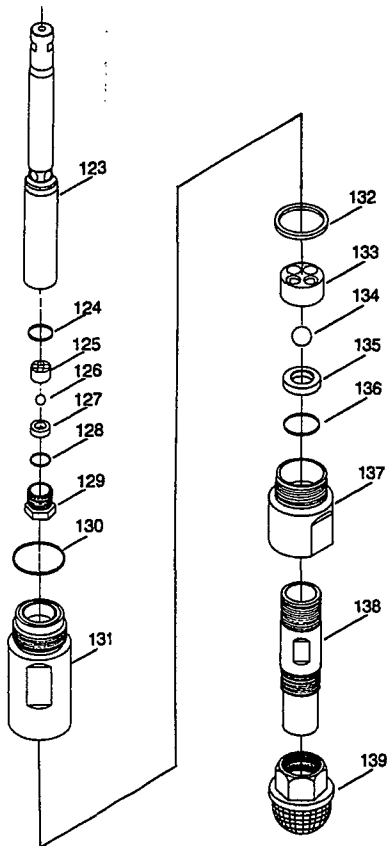

Figure 10

Pump Section Repair and Packing Replacement

WARNING: Before proceeding, follow the Pressure Relief Procedure outlined on Page 3. Additionally, follow all other warnings to reduce the risk of an injection injury, injury from moving parts or electric shock, Always unplug the sprayer before servicing!

1. Stop Sprayer at the bottom of its stroke and remove Safety Plate #142.
2. Using a 3/8" allen wrench remove four screws (#116).
3. Using a 3/4" wrench loosen the retaining nut on the Pipe Assembly (#110) from Item #120.
4. Place a screwdriver between Item #114 and #112 and lightly pry downward.
5. Pull Fluid Section Forward.
6. Place Foot Valve Housing (#137) in a vise and use a wrench on the Lower Housing (#131) to unthread.
7. Remove the Seal (#132) from inside the Lower Housing (#131).
8. Remove the Lower Cage (#133) from the Foot Valve Housing (#137).
9. Remove Ball (#134) and examine.
10. Remove Seat (#135). If damaged use other side or replace.
11. Remove Seal (#136).
12. Place the Lower Housing in a vise and use a wrench on the Upper Housing (#121) to unthread.
13. Remove Seal (#130) from outside of the Lower Housing (#131).

14. Place the Upper Housing (#121) in a vise and use a wrench on the upper Guide (#118) to unthread.
 15. Using a Plastic Mallet Tap the Piston (#123) out of the Bottom of the Upper Housing (#121).
 16. Place the Piston (#123) in the slots of the Slider (#111) which is still mounted on the unit. This will hold the Piston in-place when removing the Retainer (#129). NOTE: Never use wrench on the Piston.
 17. Remove Seal (#124) from inside of Piston (#123).
 18. Remove Upper Cage (#125) from the Retainer (#129).
 19. Remove the Upper Ball (#126) and examine.
 20. Remove Seat (#127). If damaged use the other side or replace.
 21. Remove Seal (#128) from the Retainer (#129).
 22. Remove the Upper Packing (#119) from the Upper Housing (#121).
 23. Remove both Lower Packings (#122) from inside the Upper Housing (#121). **WARNING: Always insert Packings with the raised side facing into the Upper Housing.**
 24. Assemble in reverse order.
 - Be sure to use all of the replacement parts supplied in the Repacking Kit #761-175.**
 25. Align Flats on Piston so that it is perpendicular to the Upper Mount (#114).
 26. Reattach the four screws (#116) to the Pump Mount (#114).
 27. Reattach Retaining Nut on Pipe Assembly (#110) to Connector (#120).
- NOTE: Make sure to fill the Upper Guide (#118) one-third (1/3) full with Piston Seal Lubricant.

MODEL #	SERIAL #	DATE PURCHASED	COMPANY NAME
---------	----------	----------------	--------------

Equipment Job History

In order to help you track the superior performance of your Titan Elite Pump we recommend you keep this log for your records. We feel you may find it useful for gauging on-site performance, invoicing of overtime and your estimator's reference.

Elite (G 55) / (E 20)

Circle One

Job Name	Foreman's Name	Type of Coating	Tips Used		Date Completed
			Size	Quantity	
Date Begun	Site	Gallons Sprayed			
Job Name	Foreman's Name	Type of Coating	Tips Used		Date Completed
Date Begun	Site	Gallons Sprayed	Size	Quantity	
Job Name	Foreman's Name	Type of Coating	Tips Used		Date Completed
Date Begun	Site	Gallons Sprayed	Size	Quantity	
Job Name	Foreman's Name	Type of Coating	Tips Used		Date Completed
Date Begun	Site	Gallons Sprayed	Size	Quantity	
Job Name	Foreman's Name	Type of Coating	Tips Used		Date Completed
Date Begun	Site	Gallons Sprayed	Size	Quantity	
Job Name	Foreman's Name	Type of Coating	Tips Used		Date Completed
Date Begun	Site	Gallons Sprayed	Size	Quantity	
Job Name	Foreman's Name	Type of Coating	Tips Used		Date Completed
Date Begun	Site	Gallons Sprayed	Size	Quantity	
Job Name	Foreman's Name	Type of Coating	Tips Used		Date Completed
Date Begun	Site	Gallons Sprayed	Size	Quantity	
Job Name	Foreman's Name	Type of Coating	Tips Used		Date Completed
Date Begun	Site	Gallons Sprayed	Size	Quantity	
Job Name	Foreman's Name	Type of Coating	Tips Used		Date Completed
Date Begun	Site	Gallons Sprayed	Size	Quantity	
Job Name	Foreman's Name	Type of Coating	Tips Used		Date Completed
Date Begun	Site	Gallons Sprayed	Size	Quantity	
Job Name	Foreman's Name	Type of Coating	Tips Used		Date Completed
Date Begun	Site	Gallons Sprayed	Size	Quantity	
Job Name	Foreman's Name	Type of Coating	Tips Used		Date Completed
Date Begun	Site	Gallons Sprayed	Size	Quantity	

May Be Copied For Field Use

PUMP	OPERATING PRESSURE	MAXIMUM TIP SIZE*	WEIGHT	AMP DRAW MAX' psi	MAXIMUM GPM OUTPUT	MAXIMUM HOSE LENGTH**	POWER SOURCE	PRODUCT NUMBER	PRODUCT NO. (complete with 50' hose & LX-80 Gun)
440e	0-3000 psi	.019 w/ 1 gun	27 lbs	9	.4	100 ft.	3/4 hp AC motor	700-810	700-820
660ex	0-3000 psi	.023 w/ 1 gun	56 lbs	15	.6	200 ft.	1.0 hp totally enclosed AC motor	702-075	702-080
690gx	0-3000 psi	.023 w/ 1 gun	78 lbs		.63	250 ft.	3.5 hp Honda engine	755-095	755-100
E20	0-2750 psi	.033 w/ 1 gun .023 w/ 2 guns	95 lbs	18	1.25	300 ft.	2.0 hp totally enclosed AC motor	761-502	761-500
G55	0-3000 psi	.035 w/ 1 gun .025 w/ 2 guns .019 w/ 3 guns	125 lbs		1.35	400 ft.	5.0 hp Honda engine	763-102	763-100

* At 2000 psi with Latex

** Hose length depends upon material being sprayed, hose diameter and tip size.

Elite E 20 Warranty

Titan Tool Inc. warrants to the original purchaser for a period of twelve months from the date of purchase, to repair or replace any part of the equipment proven defective, with the exception of defects in parts of the drive train/gear box, electric motor (excluding brush replacement) or pressure control assembly which will be repaired or replaced for twenty-four months from the date of the sale. This warranty applies only when the unit is installed and operated in accordance with the recommendations and instructions of Titan Tool Inc.

This limited warranty does not apply to damage or wear caused by abrasion, corrosion or misuse, negligence, accident, faulty installation or tampering in a manner to impair normal operation.

In the event of breach of this warranty Titan Tool Inc. will repair or replace such defective parts free of charge if such parts are returned to an authorized Titan Tool Inc. sales/service outlet. All transportation costs under this warranty, including return to the factory, if necessary, are to be borne by the purchaser (and prepaid by him).

There is no other express warranty. Titan Tool Inc. hereby disclaims any and all implied warranties including but not limited to, those of merchantability and fitness for a particular purpose, to the extent permitted by law. The duration of any implied warranties which cannot be disclaimed is limited to the time period as specified in the express warranty. In no case shall Titan Tool Inc.'s liability exceed the amount of the purchase price. Liability for consequential, incidental or special damages under any and all warranties is excluded to the extent permitted by law.

EQUIPMENT NOT COVERED BY THE TITAN WARRANTY

Titan Tool Inc. makes no warranty, and disclaims all implied warranties of merchantability and fitness for a particular purpose, with respect to accessories, equipment, materials or components sold but not manufactured by Titan Tool Inc. These items sold, but not manufactured by Titan Tool Inc. (such as gas engines, switches, hoses, etc.), are subject to the warranty, if any, of their manufacturer. Titan Tool Inc. will provide purchaser with reasonable assistance in making any claim for breach of these warranties.

Elite **E200**

TITAN

©1992 Titan Tool Inc.
313 - 247 Printed in the U.S.A.
AJ 2M 292

Titan Tool Inc.
107 Bauer Drive
Oakland, New Jersey 07436

1-800-526-5362
FAX 201-337-8271

Canadian Branch
200 Towers Road, Unit 7B
Woodbridge, Ontario
Canada L4L 5Z8

1-800-565-8665
FAX 1-416-856-8496